

# Yardmaster™ Magnet Controller

# 4292

Pub. 190 September 2012, Replaces July 2012

## Instructions

Lifting magnets operate more efficiently with greater life and safety to equipment when controlled by the Hubbell type 4292 Magnet Controllers. Magnets are cleanly discharged permitting prompt return for another lift because of exclusive patented features.

A mechanically rugged high thermal capacity varistor assembly permanently connected around the magnet always provides a positive, safe discharge path for the stored magnetic energy. The use of a non-linear silicon carbide material in this varistor permits the fastest possible discharge of the magnetic energy and at peak voltages not exceeding 700 volts.

Inductive voltages from the magnet discharge cannot be returned to the line, permitting rectifier power supplies to be safely used without requiring special protective load resistors or other by-pass circuitry.

Refer to the standard schematic diagram. The Lift and Drop contactors designated "1L", "2L" and "D" respectively, provide a reversing circuit to the magnet. The discharge circuit is composed of the permanently connected Discharge Varistor-"DVA" and the Blocking Rectifier-"RECT".

Throwing the master switch handle to the lift position closes the master switch contact in the lift contactor coil circuit, thereby energizing the Lift contactors. The control circuit power is supplied through "CFU" and Rectifier-"D1". This rectifier assures that correct polarity connections have been made to the controller. No operation is possible without proper polarity being supplied.

**Figure 1**  
Type 4292 Lifting  
Magnet Control  
Automatic Discharge  
Constant Voltage  
Schematic Diagram

Sym.	Function
DR	Drop Relay
P1	Potentiometer Assembly
CFU	Control Fuse
D1	Diode
Rect.	Rectifier, Magnet Discharge Path
MOV	Surge Suppressor
DVA	Discharge Varistor
DSM	Discharge Sensor Module
D	Drop Contactor
2L	List Contactor
1L	Lift Contactor

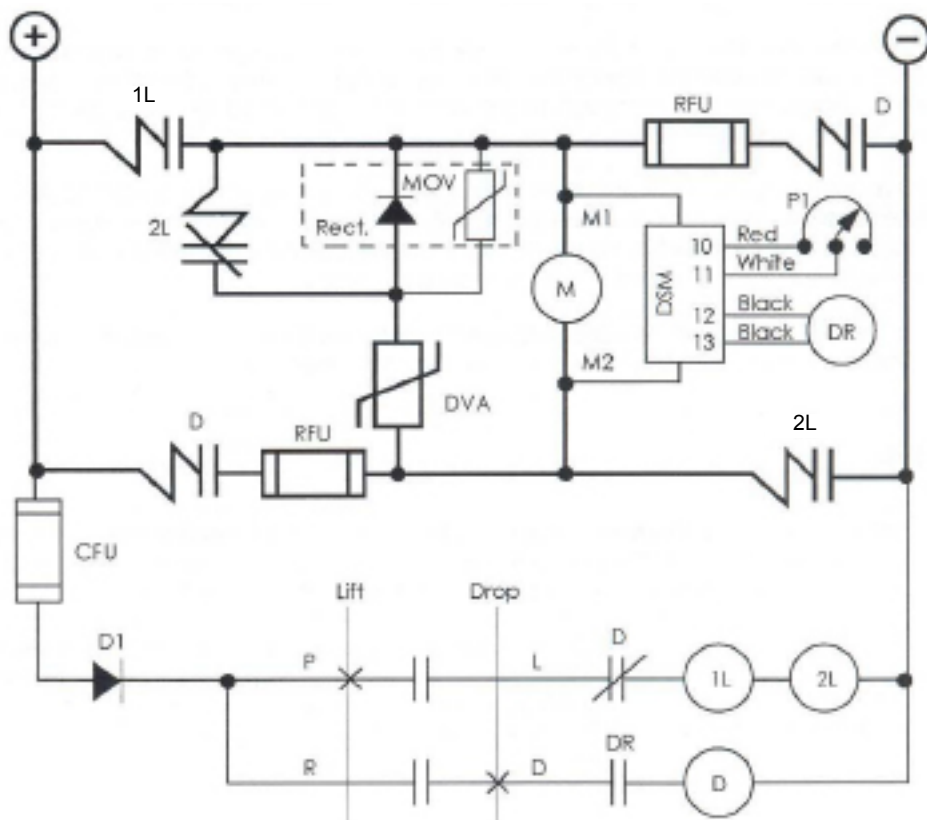

## Installation and Maintenance

Hubbell Type 4292 Magnet Controllers should be installed in accordance with accepted practice for installation of industrial control equipment. Polarity of the incoming line connections **MUST BE** observed: otherwise, these controllers will not function.

### Caution:

User should check all nuts, bolts and screws in the magnet control cabinet prior to putting the controller into operation as the nuts, bolts and screws may have become loose in transportation.

The Yardmaster is available with 230VDC, 115VDC, 12VDC or 24VDC control circuits. Insure the proper control voltage is applied. An understanding of the principle of operation will help in analyzing trouble and in keeping this controller operating at maximum efficiency.

Basically, this controller serves the three functions necessary for magnet operations:

1. Energize the magnet for movement of load
2. Dissipate the stored energy of the magnet to release the load
3. Apply reverse current through the magnet to remove the residual magnetism

Two electrically and mechanically interlocked sets of contactors, "Lift" and "Drop", serve to apply the DC power for energization and reverse current cleaning respectively in two separate actions without time overlap.

The permanently connected magnet discharge path around the magnet absorbs and dissipates the stored magnet energy when the Lift contactor interrupts the supply power.

During the stored energy dissipation cycle, the reverse voltage appearing across the magnet and the discharge varistor assembly signals the discharge sensor module "DSM" that a discharge cycle has begun. When the discharge voltage falls to 300 to 350 volts, the "DSM" module closes a pilot "DROP RELAY" which energizes the "DROP" contactor.

The fixed time reverse current cycle begins with the closing of the "DROP RELAY" after practically all of the stored magnet energy is dissipated in the discharge path. After a preset period, controlled by the Drop Time adjustment potentiometer, P1, the "DSM" de-energizes the DROP RELAY. This action causes the drop contactor to open and end the reverse current cycle.

Another unique feature of Hubbell Magnet Controllers is that full supply voltage is utilized to force the buildup of reverse current, improving the overall controller speed.

### Note:

Reverse current adjustment should always be made with the lightest material handled. Start with P1 at "O" and cycle the controller. Turn the adjustment knob clockwise and repeat cycling until the magnet drops the material cleanly. The adjusting potentiometer is mounted beside the "DSM". Since the discharge of the magnet is a separate function from the reverse current magnet cleaning action, it is easy to obtain close control of partial load drop or to "DRIBBLE" a load if desired. A portion of the load can be dropped merely by moving the master switch handle midway between the lift and drop positions to open the "LIFT" contactor without "SETTING UP" the automatic drop cycle.



## Troubleshooting

The following covers a general list of possible troubles that may be encountered, with the causes and suggested actions given respectively.

<b>SYMPTOM</b>	<b>POSSIBLE CAUSE</b>	<b>DIAGNOSIS/ACTION</b>
"Lift" contactor does not pick up.	Polarity not observed at the time of controller installation.	Reverse the supply power connections to the controller.
	Lift contactor coil circuit open	Check continuity of lift contactor coils. Check master switch contacts.
	CFU or Diode D1 open.	Replace CFU or D1
Magnet does not clean properly	Reverse current cycle time is too short. Drop contactor does not remain closed long enough to clean magnet.	Increase the Drop Time potentiometer setting (clockwise rotation).
	Reverse current cycle time is too long. Drop contactor remains closed too long and allows excessive reverse current build-up.	Decrease the Drop Time potentiometer setting (counter clockwise rotation).
	Drop contactor operates but no reverse current flows.	Replace RFU fuses.
	4292 DVA varistor circuit open.	Check DVA. If fins are warped or ohm value is under 50k ohms, varistor may be defective. Replace.
"Drop" contactor does not operate.	Drop contactor coil circuit open.	Check continuity of Drop contactor coils. Check master switch contacts.
	Reversed M2-M1 connections to the DSM.	Check DSM wiring and correct if necessary.
	Faulty drop relay.	Replace drop relay.
	Faulty DSM.	Replace DSM.
"Drop" contactor operates but does not drop.	Faulty drop time adjustment potentiometer or open potentiometer circuit.	Repair or replace potentiometer assembly or wiring.
	Faulty DSM	Replace DSM.
No adjustment of the reverse current cycle.	Faulty drop time adjustment potentiometer.	Replace potentiometer assembly.
	Faulty DSM	Replace DSM.
Magnet discharge device overheats.	Too many magnet discharges per minute.	Avoid frequent cycling or use controller with increased capacity.
	Blocking rectifier is shorted. Full line voltage applied to magnet discharge device during lift cycle.	Replace blocking rectifier assembly.



## 4292 RENEWAL PARTS

Device	Description	Service Pub.	Part Number
1L/2L	100 Amp Contactor	RPC 59364-1	*
	230 VDC Control	---	HC59364505
	125 VDC Control	---	HC59364506
	24VDC Control	---	HC59364508
	12 VDC Control	---	HC59364510
	Arc Shield Kit	Item 28	HC59673002
	Contact Kit	---	HC59672007
	Aux. Contact Kit	Item 47	HC68011001
	Coil (115/125V)	Item 17	HC17487000
	Coil (12V)	Item 17	HC17489000
	Coil (6V)	Item 17	HC82352000
	Coil (57.5V)	Item 17	HC17488000
D	50 Amp Contactor	RPC 59323-1	*
	230 VDC Control	---	HC59322103
	125 VDC Control	---	HC59322101
	24VDC Control	---	HC59322107
	12 VDC Control	---	HC59322115
	Arc Shield	Item 19	HC42856001
	Contact Kit	---	HC59672003
	Coil (230/250V)	Item 10	HC68014001
	Coil (24V)	Item 10	HC68014004
	Coil (12V)	Item 10	HC68014007
Coil (115V)	Item 10	HC68014002	
Rect.	Rect/Mov. Assy.	---	HC71386007
DVA	Discharge Varistor	---	HC03009030
DR	Drop Relay	---	HC31658038
D2	Control Diode	---	HC47288066
P1	Potentiometer Assy.	---	HC48686001
DSM	Discharge Sensor Module	---	HC48684001
RES2	Resistor, 5 OHM/100W	---	HC57419035
RFU	Reverse Current Fuse	---	HC57361758
CFU	115/230VDC Control Fuse	---	HC57361752
	24VDC Control Fuse	---	HC57361753
	12VDC Control Fuse	---	HC57361754

\* The Contactor nameplate identifies the complete contactor which varies because of control voltage.

### CONTACTOR MAINTENANCE

For proper maintenance of the "Lift" and "Drop" contactors refer to the following Hubbell Contactor Service Publications:

Contactor Size	Contactor Series	Publication Number
2 (Drop)	59322	RPC59323-1
3 (Lift)	59335	RPC59364-1



Hubbell Industrial Controls, Inc.  
 a subsidiary of Hubbell Incorporated  
 4301 Cheyenne Drive, Archdale, NC 27263  
 Phone (336) 434-2800 | Fax (336) 434-2801  
[www.hubbell-icd.com](http://www.hubbell-icd.com)  
[sales@hubbell-icd.com](mailto:sales@hubbell-icd.com)