



CLASS 8503 TYPE MXDO-1 NEMA SIZE 2, 50 AMPERE, AC CONTACTOR SINGLE POLE, NORMALLY OPEN, SERIES A

DESCRIPTION

The Class 8503 Type MX contactor is an ac magnetic, mill type, clapper device and is designed to meet NEMA Standards. The double pole contactor consists of two single pole contactors mechanically tied together with the dc operating coils connected in series.

CONTACTOR RATINGS - MAXIMUM

600 volts ac 60 Hertz 40°C Ambient

Open 8 Hour Ratings	Enclosed Ratings		Crane Ratings	
AC Amperes	AC Amperes	AC Motor Horsepower 460 vac	AC Amperes	AC Motor Horsepower 460 vac
50	45	25	67	40

OPERATING COIL DATA

DC Voltage Rating	Coil Part No.	Nominal OHMS At 20°C
115 / 120	D5-1015-056-51	543

The operating coils are designed in accordance with NEMA Standards to withstand 110% of rated voltage continuously and to operate the contactor successfully at 80% of rated voltage. Standard coil voltages are 115/120 volt dc. For other available coil voltages refer to Class 9998 Coil Data Catalog Sheet.

ELECTRICAL INTERLOCKS

Electrical interlocks are rated in accordance with NEMA Standard ICS-2-125 (A600 and N600 Table Ratings).

A600	Maximum Continuous Amperes	Maximum Make and Break Current Amperes							
		120V		240V		480V		600V	
		Make	Break	Make	Break	Make	Break	Make	Break
AC	10	60	6	30	3	15	1.5	12	1.2

N600	Maximum Continuous Amperes	Maximum Make and Break Current Amperes					
		125V		250V		600V	
		Make	Break	Make	Break	Make	Break
DC	10	2.2	2.2	1.1	1.1	.4	.4

Electrical interlocks consist of stationary contacts mounted on the contactor base (36) and movable contacts attached to the bottom of the contact arm assembly (17). A set of electrical interlocks contains one normally open and one normally closed double break contacts. Make and break ratings apply for double throw contacts only when both the normally open and normally closed contacts are connected to the same polarity.

CONTACT TIPS

Copper power contact tips are standard. Silver faced power contact tips are available and are recommended for applications where the contactors remain closed for long periods of time. Silver faced contact tips are optional on dc starters.

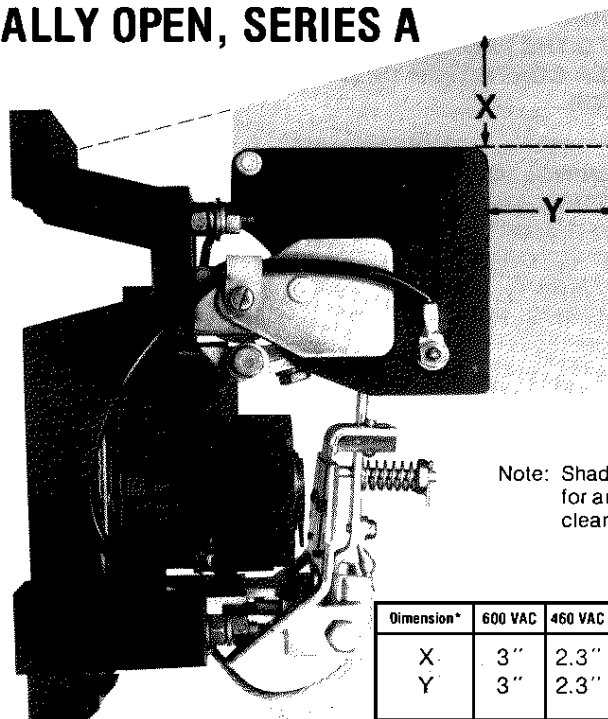

Note: Shaded area for arcing clearances.

Dimension*	600 VAC	460 VAC	230 VAC
X	3"	2.3"	1.7"
Y	3"	2.3"	1.7"

Figure 1

* To grounded, uninsulated panel
Electrical Clearances

INSTALLATION

1. Unpack contactor carefully. Remove shipping tape (if used).
2. Check nameplate data for correct equipment. Check that the contactor operating coil (32) is the correct voltage.
3. Check that all parts are undamaged and secure.
4. Mount the contactor vertically on a rigid support and fasten down tightly using a plain washer against the contactor base. Provide the clearance shown in Fig. 1 above the top of the contactor and in front of the arc chute for pivoting or removal of the arc chute and for electrical clearances.
5. With all power removed, mount auxiliary devices such as mechanical or electrical interlocks, if used, on contactor. Install and adjust these auxiliary devices by the procedure in the instruction sheets provided with the devices.
6. With all power removed, pivot the arc chute upwards and operate the contactor by hand. Check the alignment of the contact tips (14A & 14B) by the procedure in the ADJUSTMENT—Contact Tip Alignment instructions in this Service Bulletin.
7. Pivot the arc chute back to its proper position.

CAUTION: DO NOT OPERATE THE CONTACTOR UNDER LOAD UNLESS THE ARC CHUTE IS PIVOTED TO THE FULLY DOWN POSITION.

8. Check the wiring diagram before connecting the contactor coil leads, power contact leads, and interlock leads. The operating coil circuit voltage may be different from the power circuit voltage.

CAUTION: FAILURE TO CONNECT THE OPERATING COIL TO THE PROPER VOLTAGE MAY RESULT IN IMPROPER CONTACTOR OPERATION OR DAMAGE TO THE COIL.

WARNING: ALL METAL PARTS OF THE CONTACTOR MAY BE AT LINE VOLTAGE. ALL POWER MUST BE DISCONNECTED FROM THE CONTACTOR BEFORE PERFORMING ANY ADJUSTMENT, MAINTENANCE OR TROUBLESHOOTING PROCEDURES.

ADJUSTMENT

CONTACT TIP ALIGNMENT

1. With all power removed, pivot the arc chute upward.
2. Check that the movable contact tip is securely fastened to the contact arm assembly (17) with the contact arm spring, cup washer and cotter pin and that the movable contact tip is properly seated in the slot in the contact arm assembly (Fig. 2).

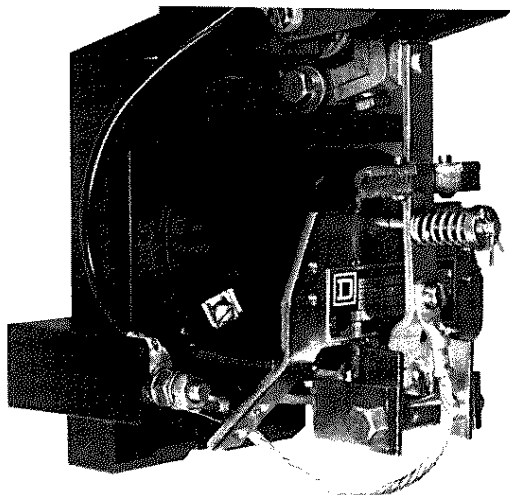

Figure 2

3. Check that the stationary contact tip is properly seated against the stationary support of the contactor (Fig. 2).
4. Pivot the arc chute back to its proper position.

CAUTION: DO NOT OPERATE THE CONTACTOR UNDER LOAD UNLESS THE ARC CHUTE IS PIVOTED TO THE FULLY DOWN POSITION.

ELECTRICAL INTERLOCKS

1. With all power removed, check that the electrical interlock (43) has the proper follow-up. With new electrical interlock contacts, the moving contacts (46) should provide at least 1/16" follow-up on each stationary contact when the contact arm reaches its limit of travel; either completely closed or completely opened (Fig. 3).

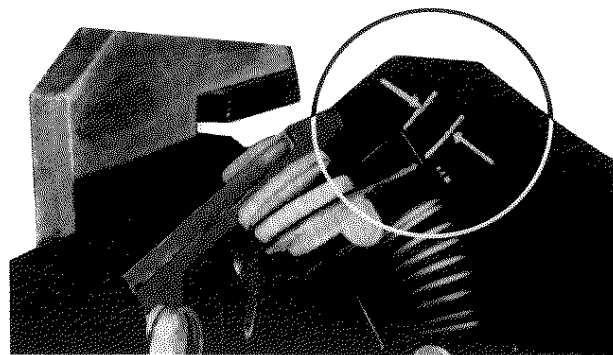

Figure 3

2. Check that the normally closed electrical interlock contacts open before the power contact tips close.
3. Electrical interlock follow-up can be adjusted by bending the stationary contacts (50 & 51).

MECHANICAL INTERLOCK

1. With all power removed, check that the mechanical interlock allows the contact arm of either contactor to reach its limit of travel, either completely closed or completely open, without binding.
2. Hold the contact arm of the left contactor fully closed and push closed the contact arm of the right contactor until stopped by the mechanical interlock. With new contact tips, check that there is a gap of at least 3/16" but not more than 1/4" between the contact tips. (Fig. 4).

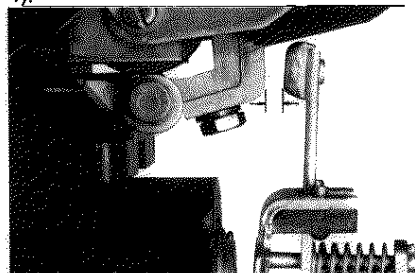

Figure 4

3. If the gap is not within the limits, adjust the mechanical interlock as follows: Loosen the two hex head screws that hold the mechanical interlock to the contactor and move the mechanical interlock until the desired gap is achieved.
4. Repeat steps 2 and 3 above holding the right contactor in the fully closed position.
5. Push in one contactor to the kiss position and check that the other contactor does not come to the kiss position at the same time.
6. If both contactors come to the kiss position at the same time, repeat steps 2 to 5 decreasing the gap but not increasing it past 1/4".
7. Again check that the mechanical interlock allows the contact arm of either contactor to reach its limit of travel, either completely closed or completely open, without binding.

CONTACT ARM GAP

1. Contact arm gap is factory adjusted. Do not change the setting of the adjusting screw (27).

2. Should the setting be inadvertently changed, readjust the contact arm gap by turning the adjusting screw (27) located on the bottom of the contact arm (Fig. 1) until a contact tip gap of 5/16" is achieved (Fig. 4).
3. Retighten the locking nut (28) which holds the adjusting screw.

WARNING: ALL METAL PARTS OF THE CONTACTOR MAY BE AT LINE VOLTAGE. ALL POWER MUST BE DISCONNECTED FROM THE CONTACTOR BEFORE PERFORMING ANY ADJUSTMENT, MAINTENANCE OR TROUBLESHOOTING PROCEDURES.

MAINTENANCE

LUBRICATION

No lubrication is required.

CONTACT TIP INSPECTION

The contact tips should be replaced when the contact follow-up is less than 1/32" (Fig. 5).

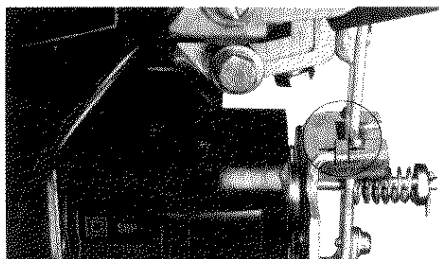

Figure 5

CONTACT TIP REPLACEMENT

1. With all power removed, pivot the arc chute upward.
2. Remove the shunt (25) by removing the 8-32 x 1/4" pan head screw (22), lockwasher (23), and washer (24) which holds it to the contact tip.
3. Remove the spring (18) by removing the cotter pin (20), cup washer (19), and the spring (18).
4. Remove the movable contact tip by lifting it over the clevis pin.
5. Remove the stationary contact tip by removing the silicon bronze hex head cap screw (15) and lockwasher (16).
6. Install the new stationary contact tip using the silicon bronze hex head cap screw and lockwasher.
7. Install the new movable contact tip over the clevis pin by inserting the lower end tang in the slot in the contact arm.
8. Replace the spring using the cup washer and cotter pin.
9. Replace the shunt using 8-32 x 1/4" pan head screw, lockwasher and washer.
10. Manually operate the contactor and check the contact tips for alignment, by the procedure in the ADJUSTMENT—Contact Tip Alignment instruction in this Service Bulletin.

CAUTION: CHECK THE ADJUSTMENT OF THE MECHANICAL INTERLOCK.

11. Pivot the arc chute back to its proper position.

CAUTION: DO NOT OPERATE THE CONTACTOR UNDER LOAD UNLESS THE ARC CHUTE IS PIVOTED TO THE FULLY DOWN POSITION.

COIL REPLACEMENT

1. With all power removed, disconnect the coil leads.
2. Remove top end of shunt (25) by removing pan head screw (22), lockwasher (23), and washer (24).
3. Remove shoulder screw (21), washer (7), lockwasher (8) and nut (9), which secure contact arm assembly (17) to magnet frame (35).
4. Remove the contact arm assembly and opening spring (26).
5. Remove cotter pin (30), coil retainer (31) and coil (32).
6. Install the new coil using the coil retainer and cotter pin.
7. Replace the contact arm assembly and opening spring using the shoulder screw, washer, lockwasher and nut.
8. Replace the top end of shunt using pan head screw, lockwasher, and washer.
9. Reconnect the coil leads.

CAUTION: CHECK CONTACT TIP ALIGNMENT AND THE ADJUSTMENT OF THE MECHANICAL INTERLOCK.

ARC CHUTE REPLACEMENT

1. With all power removed, pivot the arc chute upward.
2. Remove the stationary contact tip (14A) by removing the silicon bronze hex head cap screw (15) and lockwasher (16).

CAUTION: STATIONARY CONTACT TIP MUST BE REMOVED BEFORE ARC CHUTE CAN BE REMOVED.

3. Remove the arc chute wire by removing the bottom end of the shunt (25), two lockwashers (12) and two nuts (39) which secure arc chute wire to contactor base (Fig. 6).
4. Remove the arc chute by removing the pan head screw (5), washer (7), lockwasher (8) and nut (9).
5. Install the new arc chute using pan head screw, washer, lockwasher and nut.
6. Reconnect arc chute wire and the bottom end of the shunt (25) to the contactor base using the lockwashers and nuts (Fig. 6).
7. Reinstall the stationary contact tip using the silicon bronze hex head cap screw and lockwasher.
8. Pivot the arc chute back to its proper position.

CAUTION: DO NOT OPERATE THE CONTACTOR UNDER LOAD UNLESS THE ARC CHUTE IS PIVOTED TO THE FULLY DOWN POSITION.

SHUNT REPLACEMENT

The shunt (25) should be replaced when the flexible braided wires are broken or burned or if the wires are loose in the terminal connectors on either end of the shunt.

1. With all power removed, disconnect the bottom end of the shunt (25) by removing the two lockwashers (12) and two hex nuts (39) (Fig. 6).
2. Disconnect the top end of the shunt by removing the pan head screw (22), lockwasher (23) and washer (24) (Fig. 2).
3. Install the new shunt using the pan head screw, lockwasher and washer on the top of the shunt.
4. Reconnect the arc chute wire and the bottom end of the shunt (25) to the contactor base using the lockwashers and nuts (Fig. 6).

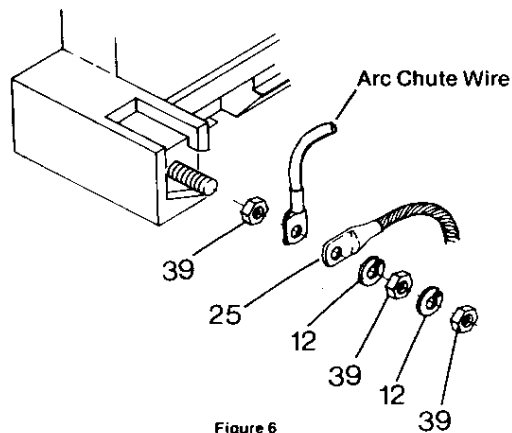

5. Pivot the arc chute back to its proper position.

CAUTION: DO NOT OPERATE THE CONTACTOR UNDER LOAD UNLESS THE ARC CHUTE IS PIVOTED TO THE FULLY DOWN POSITION.

ELECTRICAL INTERLOCK REPLACEMENT

The electrical interlock contact tips should be replaced when inspection of the contacts shows that they are burned or badly pitted. It is recommended that the entire electrical interlock assembly be replaced from a kit. However, the contact tips only can also be replaced. Note position of the leads so they can be replaced.

Electrical Interlock Assembly Replacement

1. With all power removed, loosen terminal clamps and screws and remove terminal leads from the stationary contact assembly. Note position of the leads so they can be properly replaced.
2. Remove the movable contact assembly by removing the slotted screw (44), lockwasher (45) and washer (53).
3. Remove the stationary contact assembly by removing the slotted screw (49).
4. Install new stationary contact assembly by replacing the stationary contact assembly slotted screw making sure to position stationary contact assembly as shown on the exploded view drawing.
5. Install new movable contact assembly by replacing the washers, lockwashers and slotted screws making sure to position movable contact assembly as shown on exploded view drawing.
6. Manually operate the contactor and check the moving contacts for follow-up by the procedure in the

ADJUSTMENT—Electrical Interlock instructions in this Service Bulletin.

7. Replace the terminal leads.

Electrical Interlock Contact Tip Replacement

1. After the electrical interlock assembly has been removed from the contactor, the contact tips can be replaced.
2. Remove both sets of movable contact tips (46) from the movable contact assembly by compressing the spring (48) and retainers (47) and sliding out the movable contact tips.
3. Install both sets of new movable contact tips by compressing the spring and retainers and sliding in the movable contact tips.
4. Remove both top stationary contact tips (51) from the stationary contact assembly by removing the screws and washers which hold them in place.
5. Remove the terminal clamps and screws from the top stationary contact tips.
6. Install both new top stationary contact tips by replacing the top stationary contact tips, screws, and terminal clamps and screws.
7. Remove both bottom stationary contact tips (50) from the stationary contact assembly by removing the screws and terminal clamps.
8. Install both new bottom stationary contact tips by replacing the bottom stationary contact tips, terminal clamps and screws.
9. Install the stationary and movable contact assemblies and manually operate the contactor and check the moving contacts for follow-up by the procedure in the ADJUSTMENT—Electrical Interlock instructions in this Service Bulletin.
10. Replace the terminal leads.

OPENING SPRING REPLACEMENT

1. With all power removed, pivot the arc chute upwards.
2. With all power removed, disconnect the top end of shunt by removing pan head screw (22), lockwasher (23), and washer (24).
3. Remove shoulder screw (21), washer (7), lockwasher (8) and nut (9) which secure contact arm assembly to magnet frame.
4. Remove contact arm assembly (17) and opening spring (26).
5. Install new opening spring in the slot at the bottom of the contact arm assembly.
6. Replace contact arm assembly and new opening spring using shoulder screw, washer, lockwasher and nut.
7. Replace top end of shunt using pan head screw, lockwasher, and washer.

CAUTION: CHECK CONTACT TIP ALIGNMENT AND THE ADJUSTMENT OF THE MECHANICAL INTER-LOCK.

8. Pivot the arc chute back to its proper position.

CAUTION: DO NOT OPERATE THE CONTACTOR UNDER LOAD UNLESS THE ARC CHUTE IS PIVOTED TO THE FULLY DOWN POSITION.

WARNING: ALL METAL PARTS OF THE CONTACTOR MAY BE AT LINE VOLTAGE. ALL POWER MUST BE DISCONNECTED FROM THE CONTACTOR BEFORE PERFORMING ANY ADJUSTMENT, MAINTENANCE OR TROUBLESHOOTING PROCEDURES.

TROUBLESHOOTING

Refer to the Operating Coil Table in this bulletin for coil ratings.

Refer to Contactor Ratings in this bulletin for contactor ratings.

TROUBLE	POSSIBLE CAUSE	REMEDY
Contacts will not close or operation is sluggish	<ol style="list-style-type: none"> 1. Improper or defective operating coil. 2. Low control circuit voltage. 3. Loose connection in control circuit. 4. Mechanical interference or binding. 	<ol style="list-style-type: none"> 1. Check coil part number and resistance to determine if coil is defective. 2. Check that control circuit voltage is a minimum of 80% of rated coil voltage. If it is zero, the problem is elsewhere in the circuit. 3. Check connections and tighten if loose. 4. Check for mechanical interference or binding: <ol style="list-style-type: none"> a. Check mechanical interlock interference by disconnecting it from the contactor that is binding. Refer to ADJUSTMENT—Mechanical Interlock instructions in this Service Bulletin. b. Check that the tie bar is not causing binding.
Contact tips overheating, short contact tip life.	<ol style="list-style-type: none"> 1. Loose connections. 2. Movable or stationary contact tip not properly aligned. 3. Foreign matter on contact surfaces. 4. Contact tips worn beyond recommended limits. 5. Contact surfaces severely scored or burned. 6. Arc chute not properly installed. 7. Defective opening spring. 	<ol style="list-style-type: none"> 1. Check contact tips and shunt connections and tighten if loose. 2. Check the alignment of the contact tips by the procedure listed in the ADJUSTMENT—Contact Tip Alignment instructions in this Service Bulletin. 3. Remove foreign matter. 4. Check for contact wear by the procedure listed in the MAINTENANCE—Contact Tip Replacement instructions in this Service Bulletin. 5. Inspect contact surfaces and dress with a file as required. Check that the arc chute wire is connected to the lower power terminal and is not broken. 6. Check that arc chute is pivoted to the fully down position. 7. Replace the spring.
Operating Coil Overheats	<ol style="list-style-type: none"> 1. Improper or defective coil. 2. High voltage condition on coil. 3. Loose connection at coil terminals. 	<ol style="list-style-type: none"> 1. Check coil part number and resistance to determine if coil is defective. 2. Check that control circuit voltage does not exceed 110% of rated coil voltage. 3. Check connection and tighten if loose.

**PARTS LIST FOR CLASS 8503 TYPE MXDO-1 NEMA SIZE 2, 50 AMPERE, AC CONTACTOR
SINGLE POLE, NORMALLY OPEN, SERIES A**

Item No.	Part No. ■	Description	Item No.	Part No. ■	Description
1	C51016-221-50	Arc Chute	34	A51016-210-01	Coil Core
2	B51016-213-50	Blowout Coil Assembly	35	C51016-211-01	Magnet Frame
3	A51016-217-01	Blowout Mounting Bracket	36	D51016-215-50	Contact Base
4	A51016-231-01	Blowout Core	37		1/4 - 20x 2 1/2 Round Head Machine Screw
5		10 - 24 x 1 3/4 Pan Head Screw	38		10 - 24 x 1/2 Pan Head Screw
6	25901-11080	Cable Clamp	39		1/4 - 20 Hex Nut (5 Req'd)
7		#10 Plain washer (2 Req'd)	40		1/4 - 20 x 3/4 Hex Head Machine Screw
8		#10 Lockwasher (2 Req'd)	41		1/4 - 20 x 1 Hex Head Machine Screw
9		#10-24 Hex Head Nut (2 Req'd)	42		#6 - 32 x 1/4 Tapping Screw (2 Req'd)
10	B51016-209-02	Stationary Contact Support	43	Class 9999	
11		1/4 - 20 x 7/8 Hex Head Machine Screw (2 Req'd)		Type MX-11	
12		1/4 Lockwasher (7 Req'd)		or	
13		1/4 Plain Washer (5 Req'd)		C51075-038-54	Bulk Pack of 5-Sets of Replacement Electrical Interlock Contacts consisting of
†14	Class 9998	Contact Tip Kit (Copper) Consisting of 2 Sets of Tips and Hardware			10-Movable Contact Tip (Item 46)
	Type MD-1				10-Bottom Stationary Contact Tip (Item 50)
	or				10-Top Stationary Contact Tip (Item 51)
	Class 9998	Contact Tip Kit (Silver) Consisting of 2 Sets of Silver Tips and Hardware			4-Spring Retainer (Item 47)
	Type MD-2				2-Spring (Item 48)
†14A	B50005-072-02	Stationary Contact Tip (Copper)	44		#10-24 x 1 Pan Head Screw (2 Req'd)
†14B	B51016-225-50	Movable Contact Tip (Copper)	45		#10 Lockwasher (2 Req'd)
15	21407-20160	1/4 - 20 x 1/2 Silicon Bronze Hex Head Cap Screw	46		Movable contact tip (2 Req'd)
16	23711-22000	1/4 Silicon Bronze Lockwasher	47		Spring Retainer (2 Req'd)
17	B51016-224-50	Contact Arm Assembly	48		Spring
18	B50502-602-39	Contact Arm Spring	49		#10 - 24 x 1/2 Pan Head Screw With Captive Lockwasher
19	306-D1-X1	Cup Washer	50		Bottom Stationary Contact Tip (2 Req'd)
20		1/16 x 1/2 Cotter Pin	51		Top Stationary Contact Tip (2 Req'd)
21	A51016-218-01	Shoulder Screw	52		#10 - 24 x 1/2 Captive Screw With Long Shank and Captive Lockwasher
22		8 - 32 x 1/4 Pan Head Screw	53		#10 Plain Washer (3 Req'd)
23		#8 Lockwasher			
24		#8 Plain Washer			
25	B51016-220-50	Shunt (Connector)			
26	B50502-602-40	Opening Spring			
27	A51016-232-01	Adjusting Screw			
28		1/4 - 20 Hex Nut			
29	B51139-242-05	Nameplate			
30		5/64 x 1 1/2 Cotter Pin			
31	B50502-006-28	Coil Retainer			
†32	D51015-056-51	Operating Coil (115/120 vdc)			
33	A51017-041-01	Spring Washer			

The following User Modification Kits are also available for this contactor:

Class 9999 Type MM-1 Mechanical Interlock Kit for 2 - S.P.N.O. or 2 - D.P.N.O. Contactors

Class 9999 Type MT-1 Tie Bar Kit for 2 - S.P.N.O. Contactors

Class 9999 Type MK-1 Pneumatic Timer Kit

■ Standard hardware, listed without Square D Part Number, should be obtained from a local hardware supplier.
† Parts Recommended for General Maintenance.

