



CLASS 7004 TYPE MHO-3 NEMA SIZE 6, 600 AMPERE, DC CONTACTOR SINGLE POLE, NORMALLY CLOSED, SERIES A

DESCRIPTION

The Class 7004 Type M contactor is a dc magnetic, mill-type, clapper device and is designed to meet NEMA Standards.

CONTACTOR RATINGS - MAXIMUM

600 volts dc 40°C Ambient

Open 8 Hour Ratings		Enclosed Ratings		Crane Ratings	
DC Amperes	DC Motor Horsepower @ 230 vdc	DC Amperes	DC Motor Horsepower @ 230 vdc	DC Amperes	DC Motor Horsepower @ 230 vdc
600	150	540	135	800	225

OPERATING COILS DATA

DC Voltage Rating	Coil Part No.	Nominal OHMS At 20°C
230 / 240	D5-1020-243-53	717
115 / 120	D5-1020-243-56	192

The operating coils are designed in accordance with NEMA Standards to withstand 110% of rated voltage continuously and to operate the contactor successfully at 80% of rated voltage. Standard coil voltages are 115/120 volt and 230/240 volt. For other available coil voltages refer to Class 9998 Coil Data Catalog Sheet.

ELECTRICAL INTERLOCKS

Electrical interlocks are rated in accordance with NEMA Standard ICS-2-125 (A600 and N600 Table Ratings).

A600	Maximum Continuous Amperes	Maximum Make and Break Current Amperes							
		120V		240V		480V		600V	
		Make	Break	Make	Break	Make	Break	Make	Break
AC	10	60	6	30	3	15	1.5	12	1.2

N600	Maximum Continuous Amperes	Maximum Make and Break Current Amperes					
		125V		250V		600V	
		Make	Break	Make	Break	Make	Break
DC	10	2.2	2.2	1.1	1.1	.4	.4

Electrical interlocks consist of stationary contacts mounted on the contact arm support (23) and moving contacts attached to the bottom of the contact arm (22). A set of electrical interlocks contains one normally open and one normally closed double break contacts. Make and break ratings apply for double-throw contacts only when both the normally open and normally closed contacts are connected to the same polarity.

CONTACT TIPS

The movable and stationary power contact tips are identical. Copper power contact tips are standard. Silver faced power contact tips are available and are recommended for applications where the contactors remain closed for long periods of time. Silver-faced contact tips are standard on crane manual magnetic disconnect switches and are optional on dc starters.

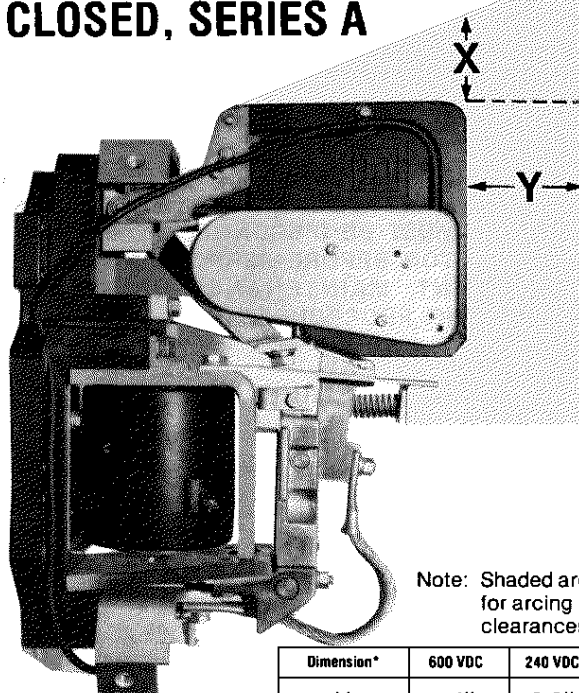

Note: Shaded area for arcing clearances.

Dimension*	600 VDC	240 VDC
X	4"	2.0"
Y	11"	2.6"

* To grounded, uninsulated panel
Electrical Clearances

Figure 1

INSTALLATION

1. Unpack contactor carefully. Remove shipping tape (if used).
2. Check nameplate data for correct equipment. Check that the contactor operating coil (36) is the correct voltage.
3. Check that all parts are undamaged and secure.
4. Mount the contactor vertically on a rigid support and fasten down tightly using a plain washer against the contactor base. Provide the clearance shown in (Fig. 1) above the top of the contactor and in front of the arc chute for pivoting or removal of the arc chute and for electrical clearances.
5. With all power removed, mount auxiliary devices such as mechanical or electrical interlocks, if used, on contactor. Install and adjust these auxiliary devices by the procedure in the instruction sheets provided with the devices.
6. With all power removed, pivot the arc chute upwards. The contact tips (10) should meet squarely. If they do not, align them by the procedure in the ADJUSTMENT—Contact Tip Alignment instructions in this Service Bulletin.
7. Pivot the arc chute back to its proper position.

CAUTION: DO NOT OPERATE THE CONTACTOR UNDER LOAD UNLESS THE ARC CHUTE IS PIVOTED TO THE FULLY DOWN POSITION.

8. Check the wiring diagram before connecting the contactor coil leads, power contact leads, and interlock leads. The operating coil circuit voltage may be different than the power circuit voltage.

CAUTION: FAILURE TO CONNECT THE OPERATING COIL TO THE PROPER VOLTAGE MAY RESULT IN IMPROPER CONTACTOR OPERATION OR DAMAGE TO THE COIL.

WARNING: ALL METAL PARTS OF THE CONTACTOR MAY BE AT LINE VOLTAGE. ALL POWER MUST BE DISCONNECTED FROM THE CONTACTOR BEFORE PERFORMING ANY ADJUSTMENT, MAINTENANCE OR TROUBLESHOOTING PROCEDURES.

ADJUSTMENT

CONTACT TIP ALIGNMENT

1. With all power removed, pivot the arc chute upward.
2. Check that the slot in the movable contact tip is engaged in the ridge located on the auxiliary arm (14) (Fig. 2). For worn contact tips refer to MAINTENANCE—Contact Tip Inspection instructions in this Service Bulletin.

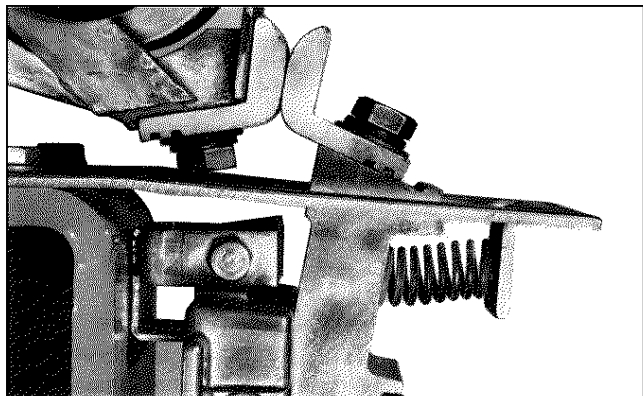

Figure 2

3. Check that the stationary contact tip is against the stationary contact support seat or the blowout coil guard (3) (Fig. 2).
4. Check that the contact tip surfaces are aligned both vertically and horizontally (Fig. 2).
5. Pivot the arc chute back to its proper position.

CAUTION: DO NOT OPERATE THE CONTACTOR UNDER LOAD UNLESS THE ARC CHUTE IS PIVOTED TO THE FULLY DOWN POSITION.

ELECTRICAL INTERLOCKS

1. With all power removed, check that the electrical interlock (46) has the proper follow-up. With new electrical interlock contacts, the moving contacts (49) should provide at least 1/16" follow-up on each sta-

tionary contact when the contact arm reaches its limit of travel; either completely closed or completely opened (Fig. 3)

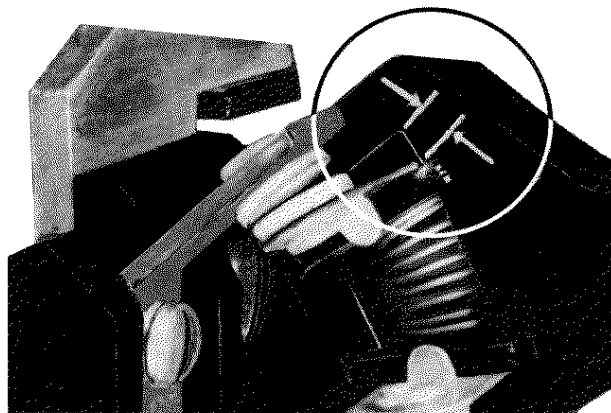

Figure 3

2. Check that the power contact tips open before the normally open electrical interlock contacts close.
3. Electrical interlock follow-up can be adjusted by bending the stationary contacts (53 & 54).

MAINTENANCE

LUBRICATION

No lubrication is required. The contactor is supplied with permanently lubricated oil impregnated bearings.

CONTACT TIP INSPECTION

The contact tips should be replaced when the contact follow-up is less than 1/16" (Fig. 4). The movable contact tip can be adjusted for additional tip life by repositioning it as shown (Fig. 4). Align the contact tip to meet squarely by the procedure in the ADJUSTMENT—Contact Tip Alignment instructions in this Service Bulletin using (Fig. 4) instead of (Fig. 2) for reference.

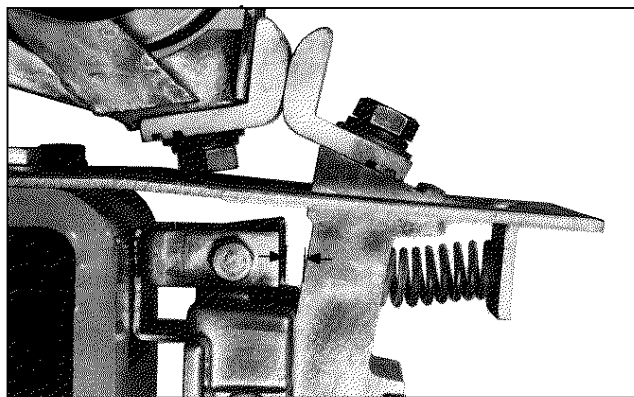

Figure 4

CONTACT TIP REPLACEMENT

1. With all power removed, pivot the arc chute upward.
2. While holding the armature plate closed, remove the movable contact tip by removing the silicon bronze hex head cap screw, lockwasher and washer located on auxiliary arm (14).

3. Remove the stationary contact tip by removing the silicon bronze hex head cap screw, lockwasher and washer located on blowout coil assembly (2).
4. Install the new stationary contact tip using the silicon bronze hex head cap screw, washer and lockwasher.
5. While holding the armature plate closed, install the new movable contact tip using the silicon bronze hex head cap screw, washer and lockwasher.
6. Manually operate the contactor and check the contact tips for alignment. Align the contact tips to meet squarely by the procedure in the ADJUSTMENT—Contact Tip Alignment instructions in this Service Bulletin.
7. Pivot the arc chute back to its proper position.

CAUTION: DO NOT OPERATE THE CONTACTOR UNDER LOAD UNLESS THE ARC CHUTE IS PIVOTED TO THE FULLY DOWN POSITION.

COIL REPLACEMENT

1. With all power removed, disconnect the coil leads.
2. Disconnect the top end of the shunt (21) by removing hex head nut, lockwasher, washer and the shunt.
3. Disconnect the armature plate from the contact arm by removing hex head screw, lockwasher, and washer. The armature plate does not have to be removed from the contactor.
4. Remove auxiliary arm spring retainer and auxiliary arm by removing hex head screws and lockwashers.
5. Slide out the contact arm pin (24) after removing the hex head nut, lockwasher, and set screw (26).
6. Remove the contact arm assembly (22).
7. Remove the magnet frame (38) from the contactor by removing hex head nuts (41) and lockwashers (8).
8. Remove the silicon bronze hex head cap screw (32) on the front of the magnet core and remove the lockwasher (33), core cap spacer (34), core cap (35) and coil (36).
9. Install the new coil using the core cap, core cap spacer and lockwasher and tighten the silicon bronze hex head screw. Note that the steel core cap, which is thicker than the non-magnetic phospher bronze spacer, must be installed against the coil. (See Exploded View). Check that the spring washer (37) is so positioned that the outside edge is against the coil (36) and not against the magnet frame.
10. Replace the magnet frame on the contactor using the lockwashers and hex head screws.
11. Replace the contact arm.
12. Replace contact arm pin and tighten set screw and hex head nut.
13. Check that auxiliary arm pin is centered and set screw is tight.
14. Replace the auxiliary arm spring retainer and spring using lockwashers and hex head screws. Check that the auxiliary arm spring is properly seated between the auxiliary arm spring retainer and the auxiliary arm (Fig. 6).
15. Connect the top end of shunt by replacing washer, lockwasher and hex head nut.
16. Reconnect the coil leads.

ARC CHUTE REPLACEMENT

1. With all power removed, disconnect the arc chute wires by removing the hex head cap screw (57), washer (45), lockwasher (6), arc chute wires and shunt (21).
2. Disassemble the arc chute wires from the contactor base.
3. Remove the arc chute by removing hex head nut (20), lockwasher (6), hex head cap screw (17) and the arc chute.
4. Install the new arc chute using hex head cap screw and lockwasher and secure with hex head nut.
5. Reposition the arc chute wires along the contactor base.
6. Reconnect arc chute wires and shunt (Fig. 5) using the washer, lockwasher and hex head cap screw.

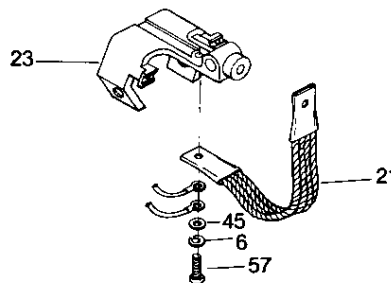

Figure 5

CAUTION: SHUNT MUST BE DIRECTLY AGAINST CONTACT ARM SUPPORT TO PROVIDE PROPER CONNECTION.

7. Rotate arc chute back to its proper position.

CAUTION: DO NOT OPERATE THE CONTACTOR UNDER LOAD UNLESS THE ARC CHUTE IS PIVOTED TO THE FULLY DOWN POSITION.

SHUNT REPLACEMENT

The shunt (21) should be replaced when the flexible braided wires are broken or burned or if the wires are loose in the terminal connectors on either end of the shunt.

1. With all power removed, disconnect the bottom end of the shunt (21) by removing hex head cap screw, lockwasher, washer, arc chute wires and the shunt.
2. Disconnect the top end of the shunt (21) by removing hex head nut, lockwasher, washer and the shunt.
3. Check that auxiliary arm pin (27) is centered and set screw (18) is tight.
4. Install the new shunt. Connect the top end of the shunt by replacing washer, lockwasher and hex head nut.
5. Connect the bottom end of the shunt by replacing the shunt, arc chute wires, washer, lockwasher and hex head cap screw (Fig. 5).

CAUTION: SHUNT MUST BE DIRECTLY AGAINST CONTACT ARM SUPPORT TO PROVIDE PROPER CONNECTION.

CAUTION: DO NOT OPERATE THE CONTACTOR UNDER LOAD UNLESS THE ARC CHUTE IS PIVOTED TO THE FULLY DOWN POSITION.

ELECTRICAL INTERLOCK REPLACEMENT

The electrical interlock contact tips should be replaced when inspection of the contacts shows that they are burned or badly pitted. It is recommended that the entire electrical interlock assembly be replaced from a kit. However, the contact tips only can also be replaced.

Electrical Interlock Assembly Replacement

1. With all power removed, loosen terminal clamps and screws (54) and remove terminal leads from the stationary contact assembly. Note position of the leads so they can be properly replaced.
2. Remove the moveable contact assembly by removing the slotted screw (47), lockwashers (48) and washers (56).
3. Remove the stationary contact assembly by removing the slotted screw (55).
4. Install new stationary contact assembly by replacing the stationary contact assembly slotted screw making sure to position stationary contact assembly as shown on the exploded view drawing.
5. Install new movable contact assembly by replacing the washers, lockwashers and slotted screws making sure to position movable contact assembly as shown on exploded view drawing.
6. Manually operate the contactor and check the moving contacts for follow-up and sequencing by the procedure in the ADJUSTMENT—Electrical Interlock instruction in this Service Bulletin.
7. Replace the terminal leads.

Electrical Interlock Contact Tip Replacement

1. After the electrical interlock assembly has been removed from the contactor the contact tips can be replaced.
2. Remove both sets of movable contact tips (49) from the movable contact assembly by compressing the spring (51) and retainers (50) and sliding out the movable contact tips.
3. Install both sets of new movable contact tips by compressing the spring and retainers and sliding in the movable contact tips.
4. Remove both top stationary contact tips (54) from the stationary contact assembly by removing the screws and washers which hold them in place.

5. Remove the terminal clamps and screws from the top stationary contact tips (54).
6. Install both new top stationary contact tips by replacing the top stationary contact tips, screws, terminal clamps and their screws.
7. Remove both bottom stationary contact tips (53) from the stationary contact assembly by removing the screws and terminal clamps.
8. Install both new bottom stationary contact tips by replacing the bottom stationary contact tips, terminal clamps and screws.
9. Manually operate the contactor and check the moving contacts for follow-up and sequencing by the procedure in the ADJUSTMENT—Electrical Interlock instruction in this Service Bulletin.
10. Replace the terminal leads.

AUXILIARY ARM SPRING REPLACEMENT

1. With all power removed, pivot the arc chute upward.
2. Remove the auxiliary arm spring retainer (16) by removing hex head screws and lockwashers.
3. Remove the auxiliary arm spring (15) from the auxiliary arm.
4. Install new auxiliary arm spring on the auxiliary arm.
5. Replace the auxiliary arm spring retainer using hex head screws and lockwashers. Check that the auxiliary arm spring is properly seated between the auxiliary arm spring retainer and the auxiliary arm (Fig. 6).
6. Pivot the arc chute back to its proper position.

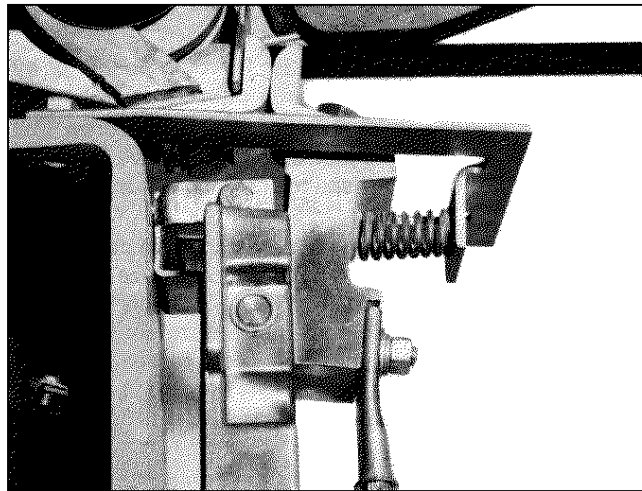

Figure 6

WARNING: ALL METAL PARTS OF THE CONTACTOR MAY BE AT LINE VOLTAGE. ALL POWER MUST BE DISCONNECTED FROM THE CONTACTOR BEFORE PERFORMING ANY ADJUSTMENT, MAINTENANCE OR TROUBLESHOOTING PROCEDURES.

TROUBLESHOOTING

Refer to the Operating Coil Table in this bulletin for coil ratings.
Refer to Contactor Ratings in this bulletin for contactor ratings.

TROUBLE	POSSIBLE CAUSE	REMEDY
Contacts will not open or operation is sluggish.	<ol style="list-style-type: none"> 1. Improper or defective operating coil. 2. Low control circuit voltage. 3. Loose connection in control circuit. 4. Mechanical interference or binding. 	<ol style="list-style-type: none"> 1. Check coil part number and resistance to determine if coil is defective. 2. Check that control circuit voltage is a minimum of 80% of rated coil voltage. If it is zero, the problem is elsewhere in the circuit. 3. Check connections and tighten if loose. 4. Check for mechanical interference or binding: <ol style="list-style-type: none"> 4a. Manually close the armature plate and check that cap screw head on core of magnet frame assembly clears the hole in the armature plate. 4b. Manually close the armature plate, check that the auxiliary arm bearings are not binding.
Contact tips overheating, short contact tip life.	<ol style="list-style-type: none"> 1. Loose connections. 2. Movable or stationary contact tip not properly aligned. 3. Foreign matter on contact surfaces. 4. Contact tips worn beyond recommended limits. 5. Contact surfaces severely scored or burned. 6. Arc chute not properly installed. 7. Defective auxiliary arm spring. 8. Normal load currents below 5% of rated current of contactor. 	<ol style="list-style-type: none"> 1. Check contact tips and shunt connections and tighten if loose. 2. Align contact tips by the procedure listed in the ADJUSTMENT—Contact Tip Alignment instructions in this Service Bulletin. 3. Remove foreign matter. 4. Check for contact wear by the procedure listed in the MAINTENANCE—Contact Tip Replacement instructions in this Service Bulletin. 5. Inspect contact surfaces and dress with a file as required. 6. Check that arc chute is pivoted to the fully down position. 7. Replace the spring. 8. Use a smaller size contactor.
Operating Coil Overheats	<ol style="list-style-type: none"> 1. Improper or defective coil. 2. High voltage condition on coil. 3. Loose connection at coil terminals. 	<ol style="list-style-type: none"> 1. Check coil part number and resistance to determine if coil is defective. 2. Check that control circuit voltage does not exceed 110% of rated coil voltage. 3. Check connection and tighten if loose.

**PARTS LIST FOR CLASS 7004 TYPE MHO-3 NEMA SIZE 6, 600 AMPERE, DC CONTACTOR
SINGLE POLE, NORMALLY CLOSED, SERIES A**

Item	Part Number	Description	Item	Part Number	Description
1	D51020-217-50	Arc Chute	34	B50502-006-15	Core Cap Spacer
2	C51020-205-50	Blowout Coil Assembly	35	B50502-006-14	Core Cap
3	C51020-252-01	Blowout Coil Guard	36	D51020-243-56 (115/120)	Operating Coil
4		5/16 - 18 x 1/2 Slotted Hex Head Screw (2 Req'd)		D51020-243-53 (230/240)	
5		3/8 - 16 x 1 Hex Head Cap Screw (6 Req'd)	37	A51020-041-01	Spring Washer
6		5/16 Lockwasher (9 Req'd)	38	C51020-226-50	Magnet Frame
7		1/4 - 20 x 3/8 Brass Flat Head Screw	39	D51020-238-50	Contact Base
8		3/8 Lockwasher (13 Req'd)	40		1/2 Bronze Plain Washer (2 Req'd)
9		6 - 32 x 1/4 Pan Head Screw (2 Req'd)	41		3/8 - 16 x 5/8 Hex Head Cap Screw (2 Req'd)
†10	Class 9998 Type MH-1 or D51020-265-53 or Class 9998 Type MH-2	Contact Tip Kit (Copper) consisting of 2 - Sets of Tips and Hardware	42		3/8 - 16 x 3/4 Hex Head Cap Screw
		Bulk Package of 30 - Copper Contact Tips	43		5/16 - 18 x 2 3/4 Hex Head Cap Screw
		Contact Tip Kit (Silver) consisting of 2 - Sets of Tips and Hardware	44	A51020-255-01	Base Plate
11		1/2 - 13 x 1 Silicon Bronze Hex Head Cap Screw (2 Req'd)	45		5/16 Plain Washer
12		3/8 - 16 Hex Head Nut	†46	Class 9999 Type MX-11 or C51075-038-54	Electrical Interlock Kit
13		1/2 Silicon Bronze Lockwasher (2 Req'd)			Bulk Pack of Replacement Electrical Interlock Contacts consisting of
14	B51020-232-50	Auxiliary Arm Assembly			10 - Movable contact tips (item 49)
15	B50502-602-30	Auxiliary Arm Spring			10 - Bottom stationary contact tip (item 53)
16	B51020-256-01	Auxiliary Arm Spring Retainer			10 - Top stationary contact tip (item 54)
17		5/16 - 18 x 3 3/4 Hex Head Cap Screw	47		4 - Spring retainer (item 50)
18		3/8 - 16 x 2 1/2 Headless Slotted Half Dog Point Set Screw	48		2 - Spring (item 51)
19		3/8 Plain Washer (4 Req'd)	49		#10 - 24 x 1 Pan Head Screw (2 Req'd)
20		5/16 - 18 Hex Head Nut	50		#10 Lockwasher (2 Req'd)
21	B51020-204-50	Connector	51		Movable contact tip (2 Req'd)
22	C51020-214-51	Contact Arm	52		Spring Retainer (2 Req'd)
23	D51020-229-50	Contact Arm Support	53		Spring
24	A51019-251-08	Contact Arm Pin	54		#10 - 24 x 1/2 Pan Head Screw with captive lockwasher
25	29005-40260	Bearing (2 Req'd)	55		Bottom stationary contact tip (2 Req'd)
26		3/8 - 16 x 1 1/4 Headless Slotted Half Dog Point Set Screw	56		Top stationary contact tip (2 Req'd)
27	A51019-251-07	Auxiliary Arm Pin	57		#10 - 24 x 1/2 Captive screw assembly with long shank and captive lockwasher
28	29005-32220	Bearing (2 Req'd)			#10 Plain Washer (3 Req'd)
29	B51020-222-50	Magnetic Latch Assembly			5/16 - 18 x 1 Hex Head Cap Screw (3 Req'd)
30	A51020-233-01	Armature Plate			
31		Nameplate			
32		5/16 - 18 x 3/4 Bronze Hex Head Cap Screw			
33		5/16 Bronze Lockwasher			

The following user modification kits are also available for this contactor:

Class 9999 Type MK-3	Pneumatic Timer Kit
Class 9999 Type ML-3	Power Lug Kit consisting of 4 - Clam Shell Lugs.

■ Standard hardware, listed without Square D Part Number, should be obtained from a local hardware supplier.
† Parts Recommended for General Maintenance.

