



CLASS 7004 TYPE MXCO-3 NEMA SIZE 1, 25 AMPERE, DC CONTACTOR SINGLE POLE, NORMALLY CLOSED, SERIES A

DESCRIPTION

The Class 7004 Type MX contactor is a dc magnetic, mill-type, clapper device and is designed to meet NEMA Standards.

CONTACTOR RATINGS - MAXIMUM

600 volts dc 40°C Ambient

Open 8 Hour Ratings		Enclosed Ratings		Crane Ratings	
DC Amperes	DC Motor Horsepower @ 230 vdc	DC Amperes	DC Motor Horsepower @ 230 vdc	DC Amperes	DC Motor Horsepower @ 230 vdc
25	5	23	4.5	34	7.5

OPERATING COILS DATA

DC Voltage Rating	Coil Part No.	Nominal OHMS At 20°C
230 / 240	D51015-056-50	2114
115 / 120	D51015-056-51	543

The operating coils are designed in accordance with NEMA Standards to withstand 110% of rated voltage continuously and to operate the contactor successfully at 80% of rated voltage. Standard coil voltages are 115/120 volt and 230/240 volt. For other available coil voltages refer to Class 9998 Coil Data Catalog Sheet.

ELECTRICAL INTERLOCKS

Electrical interlocks are rated in accordance with NEMA Standard ICS-2-125 (A600 and N600 Table Ratings).

A600	Maximum Continuous Amperes	Maximum Make and Break Current Amperes							
		120V		240V		480V		600V	
		Make	Break	Make	Break	Make	Break	Make	Break
AC	10	60	6	30	3	15	1.5	12	1.2

N600	Maximum Continuous Amperes	Maximum Make and Break Current Amperes					
		125V		250V		600V	
		Make	Break	Make	Break	Make	Break
DC	10	2.2	2.2	1.1	1.1	.4	.4

Electrical interlocks consist of stationary contacts mounted on the contactor base (36) and movable contacts attached to the bottom of the contact arm assembly (17). A set of electrical interlocks contains one normally open and one normally closed double break contacts. Make and break ratings apply for double-throw contacts only when both the normally open and normally closed contacts are connected to the same polarity.

CONTACT TIPS

Copper power contact tips are standard. Silver faced power contact tips are available and are recommended for applications where the contactors remain closed for long periods of time. Silver faced contact tips are optional on dc starters.

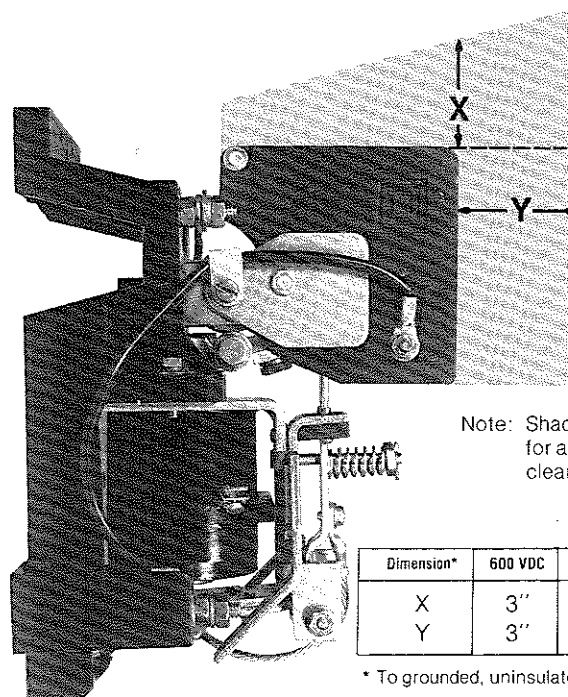

Dimension*	600 VDC	240 VDC
X	3"	1.7"
Y	3"	1.7"

* To grounded, uninsulated panel
Electrical Clearances

Figure 1

INSTALLATION

1. Unpack contactor carefully. Remove shipping tape (if used).
2. Check nameplate data for correct equipment. Check that the contactor operating coil (32) is the correct voltage.
3. Check that all parts are undamaged and secure.
4. Mount the contactor vertically on a rigid support and fasten down tightly using a plain washer against the contactor base. Provide the clearances shown in (Fig. 1) above the top of the contactor and in front of the arc chute for pivoting or removal of the arc chute and for electrical clearances.
5. With all power removed, mount auxiliary devices such as electrical interlocks, if used, on contactor. Install and adjust these auxiliary devices by the procedure in the instruction sheets provided with the devices.
6. With all power removed, pivot the arc chute upwards and check the alignment of the contact tips (14A & 14B) by the procedure in the ADJUSTMENT—Contact Tip Alignment instructions in this Service Bulletin.
7. Pivot the arc chute back to its proper position.

CAUTION: DO NOT OPERATE THE CONTACTOR UNDER LOAD UNLESS THE ARC CHUTE IS PIVOTED TO THE FULLY DOWN POSITION.

8. Check the wiring diagram before connecting the contactor coil leads, power contact leads, and interlock leads. The operating coil circuit voltage may be different than the power circuit voltage.

CAUTION: FAILURE TO CONNECT THE OPERATING COIL TO THE PROPER VOLTAGE MAY RESULT IN IMPROPER CONTACTOR OPERATION OR DAMAGE TO THE COIL.

WARNING: ALL METAL PARTS OF THE CONTACTOR MAY BE AT LINE VOLTAGE. ALL POWER MUST BE DISCONNECTED FROM THE CONTACTOR BEFORE PERFORMING ANY ADJUSTMENT, MAINTENANCE OR TROUBLESHOOTING PROCEDURES.

ADJUSTMENT

CONTACT TIP ALIGNMENT

1. With all power removed, pivot the arc chute upward.
2. Check that the movable contact tip is securely fastened to the contact arm assembly (17) with the contact arm spring, cup washer and cotter pin and that the movable contact tip is properly seated in the slot in the contact arm assembly (Fig. 2).

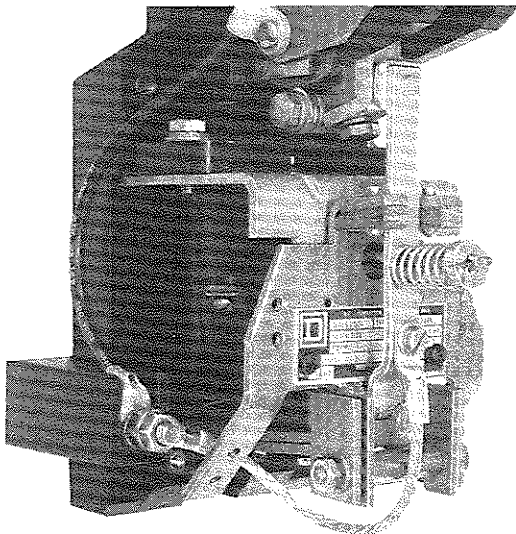

Figure 2

3. Check that the stationary contact tip is properly seated against the stationary support of the contactor (Fig. 2).
4. Pivot the arc chute back to its proper position.

CAUTION: DO NOT OPERATE THE CONTACTOR UNDER LOAD UNLESS THE ARC CHUTE IS PIVOTED TO THE FULLY DOWN POSITION.

ELECTRICAL INTERLOCKS

1. With all power removed, check that the electrical interlock (43) has the proper follow-up. With new electrical interlock contacts, the moving contacts (46) should provide at least 1/16" follow-up on each stationary contact when the contact arm reaches its limit of travel; either completely closed or completely opened (Fig. 3)

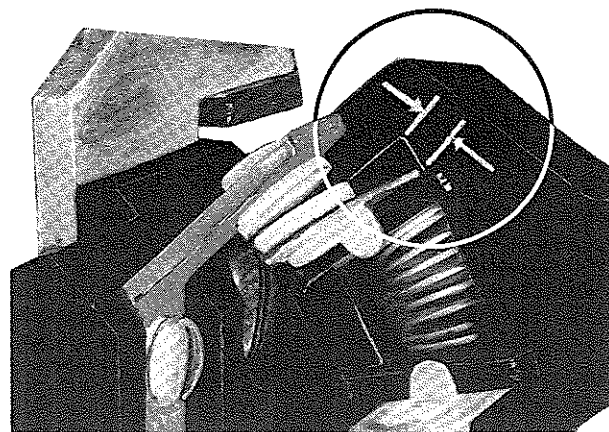

Figure 3

2. Check that the power contact tips open before the normally open electrical interlock contacts close.
3. Electrical interlock follow-up can be adjusted by bending the stationary contacts (50 & 51).

MAINTENANCE

LUBRICATION

No lubrication is required.

CONTACT TIP INSPECTION

The contact tips should be replaced when the contact follow-up is less than 1/32" (Fig. 4).

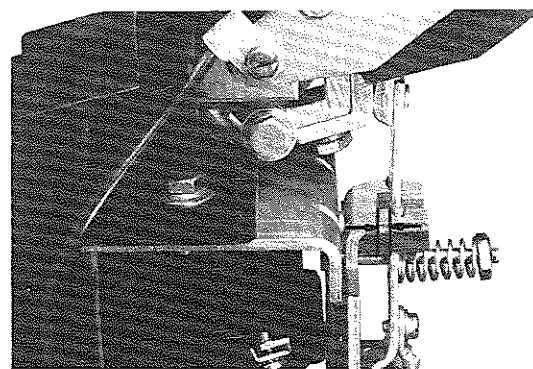

Figure 4

CONTACT TIP REPLACEMENT

1. With all power removed, pivot the arc chute upward.
2. Remove the shunt by removing the 8-32 x 1/4" pan head screw, lockwasher and washer which holds it to the contact tip.
3. Remove the spring by removing the cotter pin, cup washer, and the spring.
4. Remove the movable contact tip by lifting it over the clevis pin.
5. Remove the stationary contact tip by removing the silicon bronze hex head cap screw and lockwasher.
6. Install the new stationary contact tip using the silicon bronze hex head cap screw and lockwasher.
7. Install the new movable contact tip over the clevis pin by inserting the lower end tang in the slot in the contact arm.

8. Replace the spring using the cup washer and cotter pin.
9. Replace the shunt using 8-32 x 1/4" pan head screw, lockwasher and washer.
10. Manually operate the contactor and check the contact tips for alignment by the procedure listed in the ADJUSTMENT—Contact Tip Alignment instructions in this Service Bulletin.
11. Pivot the arc chute back to its proper position.

CAUTION: DO NOT OPERATE THE CONTACTOR UNDER LOAD UNLESS THE ARC CHUTE IS PIVOTED TO THE FULLY DOWN POSITION.

COIL REPLACEMENT

1. With all power removed, disconnect coil leads.
2. Remove top end of shunt (22) by removing pan head screw, lockwasher and washer.
3. Remove shoulder screw (21), washer, lockwasher and nut which secure contact arm assembly (17) to magnet frame (35).
4. Remove contact arm assembly (17) and armature plate assembly (26).
5. Remove the magnet frame (35) and coil (32) from the contactor base by removing the two hex head machine screws, washers and lockwashers.
6. Remove cotter pin (30), coil retainer (31) and coil (32).
7. Install new coil using coil retainer and cotter pin.
8. Replace magnet frame and coil using two hex head machine screws, washers and lockwashers.
9. Replace the contact arm assembly and armature plate assembly to magnet frame using shoulder screw, washer, lockwasher and nut.
10. Replace the top end of the shunt using pan head screw, lockwasher, and washer.
11. Reconnect coil leads.

ARC CHUTE REPLACEMENT

1. With all power removed, pivot the arc chute upward.
2. Remove the stationary contact tip (14A) by removing the silicon bronze hex head cap screw and lockwasher.
3. Remove the arc chute wire by removing the bottom end of the shunt (22), two lockwashers and two nuts which secure arc chute wire to contactor base.
4. Remove the arc chute by removing the pan head screw (5), washer, lockwasher and nut.
5. Install the new arc chute using pan head screw, washer, lockwasher and nut.
6. Reconnect the arc chute wire and the bottom end of the shunt (22) to the contactor base using the lockwashers and nuts (Fig. 5).
7. Reinstall the stationary contact tip using the silicon bronze hex head cap screw and lockwasher.
8. Pivot the arc chute back to its proper position.

CAUTION: DO NOT OPERATE THE CONTACTOR UNDER LOAD UNLESS THE ARC CHUTE IS PIVOTED TO THE FULLY DOWN POSITION.

SHUNT REPLACEMENT

The shunt (22) should be replaced when the flexible braided wires are broken or burned or if the wires are loose in the terminal connectors on either end of the shunt.

1. With all power removed, disconnect the bottom end of the shunt (22) by removing the two lockwashers and the two hex nuts.
2. Disconnect the top end of the shunt by removing the pan head screw, lockwasher and washer.
3. Install the new shunt using the pan head screw, lockwasher and washer on the top end of shunt.
4. Reconnect the arc chute wire and the bottom end of the shunt (22) to the contactor base using the lockwashers and nuts (Fig. 5).

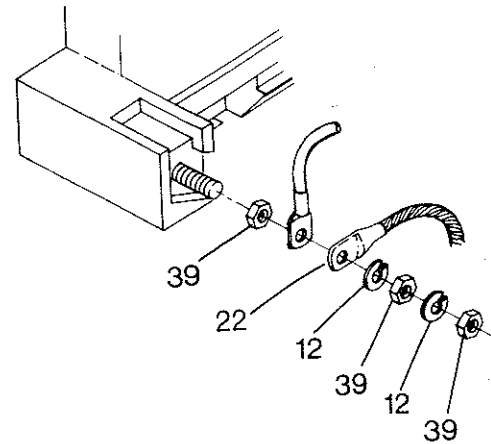

Figure 5

CAUTION: DO NOT OPERATE THE CONTACTOR UNDER LOAD UNLESS THE ARC CHUTE IS PIVOTED TO THE FULLY DOWN POSITION.

ELECTRICAL INTERLOCK REPLACEMENT

The electrical interlock contact tips should be replaced when inspection of the contacts shows that they are burned or badly pitted. It is recommended that the entire electrical interlock assembly be replaced from a kit. However, the contact tips only can also be replaced.

Electrical Interlock Assembly Replacement

1. With all power removed, loosen terminal clamps and screws and remove terminal leads from the stationary contact assembly. Note the position of the leads so they can be properly replaced.
2. Remove the movable contact assembly by removing the slotted screws (44), lockwashers (45) and washers (53).
3. Remove the stationary contact assembly by removing the slotted screw (49).
4. Install new stationary contact assembly by replacing the stationary contact assembly slotted screw making sure to position stationary contact assembly as shown on the exploded view drawing.
5. Install new movable contact assembly by replacing the washers, lockwashers and slotted screws making sure

to position movable contact assembly as shown on exploded view drawing.

6. Manually operate the contactor and check the moving contacts for follow-up and sequencing by the procedure in the ADJUSTMENT—Electrical Interlocks instructions in this Service Bulletin.
7. Replace the terminal leads.

Electrical Interlock Contact Tip Replacement

1. After the electrical interlock assembly has been removed from the contactor, the contact tips can be replaced.
2. Remove both sets of movable contact tips (46) from the movable contact assembly by compressing the spring (48) and retainers (47) and sliding out the movable contact tips.
3. Install both sets of new movable contact tips by compressing the spring and retainers and sliding in the movable contact tips.
4. Remove both top stationary contact tips (51) from the stationary contact assembly by removing the screws and washers which hold them in place.
5. Remove the terminal clamps and screws from the top stationary contact tips (51).

6. Install both new top stationary contact tips by replacing the top stationary contact tips, screws, terminal clamps and their screws.
7. Remove both bottom stationary contact tips (50) from the stationary contact assembly by removing the screws and terminal clamps.
8. Install both new bottom stationary contact tips by replacing the bottom stationary contact tips, terminal clamps and screws.
9. Manually operate the contactor and check the moving contacts for follow-up and sequencing by the procedure in the ADJUSTMENT—Electrical Interlocks instructions in this Service Bulletin.
10. Replace the terminal leads.

CLOSING SPRING REPLACEMENT

1. With all power removed, remove cotter pin (20), and cup washer (19).
2. Remove old closing spring and replace with new spring.
3. Fasten new closing spring down using cotter pin and cup washer.
4. Pivot the arc chute back to its proper position.

WARNING: ALL METAL PARTS OF THE CONTACTOR MAY BE AT LINE VOLTAGE. ALL POWER MUST BE DISCONNECTED FROM THE CONTACTOR BEFORE PERFORMING ANY ADJUSTMENT, MAINTENANCE OR TROUBLESHOOTING PROCEDURES.

TROUBLESHOOTING

Refer to the Operating Coil Table in this bulletin for coil ratings.

Refer to Contactor Ratings in this bulletin for contactor ratings.

TROUBLE	POSSIBLE CAUSE	REMEDY
Contacts will not open or operation is sluggish.	<ol style="list-style-type: none"> 1. Improper or defective operating coil. 2. Low control circuit voltage. 3. Loose connection in control circuit. 4. Mechanical interference or binding. 	<ol style="list-style-type: none"> 1. Check coil part number and resistance to determine if coil is defective. 2. Check that control circuit voltage is a minimum of 80% of rated coil voltage. If it is zero, the problem is elsewhere in the circuit. 3. Check connections and tighten if loose. 4. Check for mechanical interference or binding.
Contact tips overheating, short contact tip life.	<ol style="list-style-type: none"> 1. Loose connections. 2. Movable or stationary contact tip not properly aligned. 3. Foreign matter on contact surfaces. 4. Contact tips worn beyond recommended limits. 5. Contact surfaces severely scored or burned. 6. Arc chute not properly installed. 7. Defective closing spring. 8. Normal load currents below 5% of rated current of contactor. 	<ol style="list-style-type: none"> 1. Check contact tips and shunt connections and tighten if loose. 2. Check the alignment of the contact tips by the procedure listed in the ADJUSTMENT—Contact Tip Alignment instructions in this Service Bulletin. 3. Remove foreign matter. 4. Check for contact wear by the procedure listed in the MAINTENANCE—Contact Tip Replacement instructions in this Service Bulletin. 5. Inspect contact surfaces and dress with a file as required. 6. Check that arc chute is pivoted to the fully down position. 7. Replace the spring. 8. Use a smaller size contactor.
Operating Coil Overheats	<ol style="list-style-type: none"> 1. Improper or defective coil. 2. High voltage condition on coil. 3. Loose connection at coil terminals. 	<ol style="list-style-type: none"> 1. Check coil part number and resistance to determine if coil is defective. 2. Check that control circuit voltage does not exceed 110% of rated coil voltage. 3. Check connection and tighten if loose.

**PARTS LIST FOR CLASS 7004 MXCO-3 NEMA SIZE 1, 25 AMPERE, DC CONTACTOR
SINGLE POLE, NORMALLY CLOSED, SERIES A**

Item	Part No. ■	Description	Item	Part No. ■	Description
1	C51016-221-50	Arc Chute	33	A51017-041-01	Spring Washer
2	B51015-205-50	Blowout Coil Assembly	34	A51016-210-01	Coil Core
3	C51016-217-01	Blowout Coil Mounting Bracket	35	A51016-208-50	Magnet Frame
4	A51016-231-01	Blowout Core	36	D51016-215-50	Contactor Base
5		10 - 24 x 1 3/4 Pan Head Screw	37	A51016-241-01	Clevis Pin
6	25901-11080	Cable Clamp	38		1/4 - 20 x 2 1/2 Pan Head Screw
7		#10 Plain Washer (2 Req'd)	39		1/4 - 20 Hex Nut (5 Req'd)
8		#10 Lockwasher (4 Req'd)	40		1/4 - 20 x 1 Hex Head Machine Screw
9		#10 - 24 Hex Nut (2 Req'd)	41		10 - 24 x 1/2 Pan Head Screw (2 Req'd)
10	B51016-209-02	Stationary Contact Support	42		1/4 - 20 x 3/4 Hex Head Machine Screw (2 Req'd)
11		1/4 - 20 x 7/8 Hex Head Machine Screw (1 Req'd)	†43	Class 9999	
12		1/4 Lockwasher (8 Req'd)		Type MX-11	
13		1/4 Plain Washer (6 Req'd)		or	
†14	Class 9998	Contact Tip Kit (Copper) Consisting of		C51075-038-54	Bulk Pack of 5 - Sets of Replacement Electrical Interlock Contacts Consisting of:
	Type MD-1	2 Sets of Tips and Hardware			10 - Movable Contact Tip (Item 46)
	or				10 - Bottom Stationary Contact Tip (Item 50)
	D51016-253-53	Bulk Pack of 15 Sets - Copper Contact Tips			10 - Top Stationary Contact Tip (Item 51)
	or				4 - Spring Retainer (Item 47)
	Class 9998	Contact Tip Kit (Silver) Consisting of			2 - Spring (Item 48)
	Type MD-2	2 Sets of Silver Tips and Hardware			#10 - 24 x 1 Pan Head Screw (2 Req'd)
15	21407-20160	1/4 - 20 x 1/2 Silicon Bronze Hex Head Cap Screw			#10 Lockwasher (2 Req'd)
16	23711-22000	1/4 Silicon Bronze Lockwasher			Movable Contact Tip (2 Req'd)
17	B51016-224-50	Contact Arm Assembly	44		Spring Retainer (2 Req'd)
18	B50502-602-41	Closing Spring	45		Spring
19	306-D1-X1	Cup Washer	46		#10 - 24 x 1/2 Pan Head Screw With Captive Lockwasher (1 Req'd)
20		1/16 x 1/2 Cotter Pin	47		Bottom Stationary Contact Tip (2 Req'd)
21	A51016-218-01	Shoulder Screw	48		Top Stationary Contact Tip (2 Req'd)
22	B51016-220-50	Shunt	49		#10 - 24 x 1/2 Captive Screw With Long Shank and Captive Lockwasher (1 Req'd)
23		8 - 32 x 1/4 Pan Head Screw			#10 Plain Washer (3 Req'd)
24		#8 Lockwasher	50		#10 - 24 x 3/8 Pan Head Screw (2 Req'd)
25		#8 Plain Washer	51		
26	B51016-232-50	Armature Plate Assembly	52		
27		1/4 - 20 x 5/8 Hex Head Machine Screw			
28	B51139-242-03	Nameplate	53		
29		#6 - 32 x 1/4 Tapping Screw (2 Req'd)	54		
30		5/64 x 1 1/2 Cotter Pin			
31	B50502-006-28	Coil Retainer			
32	D51015-056-50	Operating Coil (230/240V)			
	or				
	D51015-056-51	Operating Coil (115/120V)			

The following User Modification Kit is also available for this contactor:
Class 9999 Type MK-1 Pneumatic Timer Kit

■ Standard hardware, listed without Square D Part Number, should be obtained from a local hardware supplier.
† Parts Recommended for General Maintenance.

