

# Crane Control Class 6121

Catalog

# 03

CRANE CONTROL  
CLASS 6121



## CONTENTS

Description	Page
General Information and Pricing	44
Controller Modifications and Application Data	48
Wiring Diagrams	54
Application Data	56
Dimensions and Weights	58
Rectified DC Constant Potential HWR Hoist Control	60
DC Mill Auxiliary Control	62



The Electric Controller and  
Manufacturing Company, LLC

# Crane Control Class 6121

## Frontline® DC Crane Control

CRANE CONTROL CLASS 6121



**CLASS 6121 Type EGH3  
Hoist Controller**

### GENERAL INFORMATION AND PRICING

#### Hoist Service

Class 6121 reversing dynamic lowering controllers are recommended for use with DC series motors on crane hoist drives without mechanical load brakes. These controllers are frequently used on such special mill equipment as charging machines, forging manipulators, etc. All controllers are arranged for use with series brakes.

- Mill Duty Class 7004 Type M Line-Arc® contactors & Class 7001 Type K relays
- Class 7001 Type ST-1 static acceleration timer

The standard single motor reversing dynamic lowering controller consists of:

- 1 Two pole fused control circuit knife switch (CSW)
- 1 Two pole unfused main line knife switch with padlock clip (LSW)
- 4 Type M single pole contactors with mechanical interlocks for hoisting and lowering circuits (H, 1L, 2L, 3L)
- 1 Type M single pole negative line contactor (M)
- 4 or 5 Type M single pole acceleration contactors (1A, 2A, 3A, 4A, 5A)
- 3 or 4 Type ST-1 static acceleration timers (1AR, 2AR, 3AR, 4AR)
- 1 Type KE voltage relay for acceleration lowering (VR)
- 1 Type KE limit switch relay (LSR)
- 1 Type M single pole spring-closed dynamic lowering contactor (DB)
- 1 Undervoltage relay (UV)
- 2 Magnetic overload relays (one instantaneous and one inverse time) (1OL, 2OL)

The duplex controller consists of the equipment for a single motor controller with the exception that all contactors are double pole devices and the following equipment is added:

- 1 Two pole main line knife switch with padlock clip (2LSW)
- 1 Type KE limit switch relay (2LSR)
- 2 Magnetic overload relays (one instantaneous and one inverse time) (21OL, 22OL)

VDC	Max. HP Crane Rating	Contactors NEMA Size	No. of Speed Points	Open Type		General Purpose Enclosure NEMA Type 1 Gasketed		Outdoor Enclosure NEMA Type 3R		Industrial Enclosure NEMA Type 12 ▲	
				Controller Type	Price	Controller Type	Price	Controller Type	Price	Controller Type	Price
<b>Single Motor Control ★</b>											
230	35	3	5	EOH3	\$ 15804.	ESH3	\$ 21258.	EWH3	\$ 22338.	EAH3	\$ 24804.
	55	4	5	FOH3	19008.	FSH3	24462.	FWH3	25542.	FAH3	28008.
	110	5	5	GOH3	25866.	GSH3	31995.	GWH3	33075.	GAH3	36216.
	150	5A †	5 ■	GAOH3	29747.	GASH3	36795.	GAWH3	38037.	GAAH3	41649.
	225	6	6	HOH3	42477.	HSH3	50631.	HWH3	51711.	HAH3	56877.
	275	6A †	6	HAOH3	50940.	HASH3	59054.	HAWH3	60174.	HAAH3	65340.
	500	8	6	KOH3	96129.	KSH3	106848.	KWH3	107928.	KAH3	115659.
<b>Duplex Motor Control (2 Motors Connected In Parallel) ★</b>											
230	220 (2-110)	5	5	GOH4	\$ 51714.	GSH4	\$ 63972.	GWH4	\$ 66132.	GAH4	\$ 72414.
	300 (2-150)	5A †	5 ■	GAOH4	59493.	GASH4	73590.	GAWH4	76074.	GAAH4	83298.
	450 (2-225)	6	6	HOH4	84954.	HSH4	101262.	HWH4	103422.	HAH4	113754.
	550 (2-275)	6A †	6	HAOH4	101880.	HASH4	118188.	HAWH4	120348.	HAAH4	130680.
	1000 (2-500)	8	6	KOH4	192240.	KSH4	213228.	KWH4	215838.	KAH4	231300.

▲ Non-ventilated NEMA Type 12 enclosures are not recommended for CMAA Service Classifications E and F and for applications which have frequent jogging and inching operations because a corrosive atmosphere, detrimental to the component parts, can develop. For these applications, NEMA 1 Gasketed enclosures are recommended.

★ For explanation and pricing of multi-motor controls, refer to multi-motor drives section of application data.

† Not a NEMA Size/Rating.

■ NEMA standards require 6 speed points above 110HP. Add 1 speed point if required.

#### Ordering Information Required:

1. Class
2. Type
3. Motor Horsepower at 230 VDC
4. Motor Duty Rating
5. Controller Modifications:  
Specify Form Numbers
6. Resistor Service Classification
7. Master Switch Class, Type and Form

CP9A		Discount Schedule
------	--	----------------------



**PRICING INFORMATION AND APPLICATION DATA**

**Hoist Service**

A complete set of motor control equipment consists of a controller, separately mounted Tab-Weld® resistors, and a master switch. The following tables are for selecting the resistors and master switches used with Class 6121 Hoist controllers.



**Class 6715  
Tab-Weld® Resistor**



**Class 9004  
Type CG12  
Master Switch**



**Class 9004  
Type VG12  
Master Switch**

**Tab-Weld® Resistor Selection Table** ★ †

Maximum HP Rating Single Motor ■	Price		Price Additions
	NEMA Class ●		Teaser Field Resistor ▲
	162-DL	172-DL	
5	\$ 4392.	\$ 4392.	\$ 2745.
7-1/2	3780.	3780.	1845.
10	3123.	3294.	1845.
15	3330.	3627.	945.
20	3555.	4464.	945.
25	3780.	5292.	945.
30	4392.	6147.	945.
35	5040.	7056.	945.
40	5634.	7884.	945.
45	6273.	8784.	1530.
50	6903.	9666.	1530.
60	8091.	11331.	1530.
65	8757.	12258.	1530.
70	9351.	13095.	1845.
75	9990.	13986.	1845.
90	11808.	16533.	1845.
100	13068.	18297.	1845.
135	17388.	24345.	3015.
150	19224.	26910.	3015.
200	25416.	35586.	3780.
250	32346.	45288.	5265.
275	35415.	49581.	5985.
300	38475.	53865.	5985.
325	41643.	58302.	6570.
375	47817.	66951.	6570.
500	64688.	90576.	11430.

- ★ It is recommended that hoist resistors be selected based on the 1/2 hour motor horsepower rating unless specified otherwise.
- † For resistors mounted in racks – refer to Class 6715.
- Duplex controllers require two sets of resistors, one set for each motor.
- Class 162 is recommended for standard crane duty.  
Class 172 is recommended for severe crane duty.  
Consult factory for other NEMA Classes.  
For explanation of NEMA Resistor Classifications – refer to Class 6715 Application Data.
- ▲ Teaser field resistor limits no load hoisting speed to 250% of motor rated speed. No modification of the controller is required.

**Master Switch Selection Table**

Class 9004 VM or CM NEMA 1 Enclosed						
Drive	Speed Points	Control Type	VM		CM	
			Type	Price	Type	Price
Hoist	5	W	VG12	\$ 2775.	CG12	\$ 3213.
	6	W	VG16	4319.	CG16	4665.

**Modifications**

Description	Optional Feature Form Letter	Price Addition	
		VM	CM
Spring Return to Off Point	S	\$ 444.	\$ 444.

**Accessories**

Brakes ..... see Class 5010 or 5015  
 Manual-Magnetic Disconnect Switch ..... see Class 6140  
 YOUNGSTOWN® Power Limit Switch ..... see Class 6170

CP9A  Discount Schedule

**CRANE CONTROL  
CLASS 6121**



# Crane Control Class 6121

## Frontline® DC Crane Control

CRANE CONTROL CLASS 6121



Class 6121 Type EGR3 Bridge Controller

### GENERAL INFORMATION AND PRICING

#### Bridge or Trolley Service

Class 6121 reversing plugging controllers are recommended for use with DC series motors on crane travel drives. These controllers are frequently used on such special mill equipment as charging machines, forging manipulators, etc. All controllers are arranged for use with series brakes. Shunt brakes can be used when a brake relay is added to the controller.

- Mill Duty Class 7004 Type M Line-Arc® contactors & Class 7001 Type K relays
- Class 7001 Type ST-1 static acceleration timers

The standard single motor reversing dynamic lowering control consists of:

- 1 Two pole fused control circuit knife switch (CSW)
- 1 Two pole unfused main line knife switch with padlock clip (LSW)
- 4 Type M single pole directional contactors with mechanical interlocks (1F, 2F, 1R, 2R)
- 1 Type M single pole negative line contactor (M)
- 4 or 5 Type M single pole acceleration contactors (including one for plugging) (1A, 2A, 3A, P)
- 3 or 4 Type ST-1 static acceleration timers (1AR, 2AR, 3AR, 4AR)
- 1 Type KP rectifier-plugging relay (PR)
- 1 Undervoltage relay (UV)
- 2 Magnetic overload relays (one instantaneous and one inverse time) (1OL, 2OL)

The duplex controller consists of the equipment for a single motor controller with the exception that all contactors are double pole devices and the following equipment is added:

- 1 Two pole main line knife switch with padlock clip (2LSW)
- 1 Type KP rectifier-plugging relay (2PR)
- 2 Magnetic overload relays (one instantaneous and one inverse time) (21OL, 22OL)

VDC	Max. HP Crane Rating ●	Contactors NEMA Size	No. of Speed Points	Open Type		General Purpose Enclosure NEMA Type 1 Gasketed		Rainproof and Sleet-Resistant Enclosure NEMA Type 3R		Industrial Enclosure NEMA Type 12 ▲	
				Controller Type	Price	Controller Type	Price	Controller Type	Price	Controller Type	Price
<b>Single Motor Control ★</b>											
230	35	3	5	EOR3	\$ 14670.	ESR3	\$ 20124.	EWR3	\$ 21204.	EAR3	\$ 23670.
	55	4	5	FOR3	17352.	FSR3	22806.	FWR3	23886.	FAR3	26352.
	110	5	5	GOR3	23652.	GSR3	29781.	GWR3	30861.	GAR3	34002.
	150	5A †	5 ■	GAOR3	27200.	GASR3	34248.	GAWR3	35490.	GAAR3	39102.
	225	6	6	HOR3	38880.	HSR3	47034.	HWR3	48114.	HAR3	53280.
<b>Duplex Motor Control (2 Motors Connected in Parallel) ★</b>											
230	70 (2-35)	3	5	EOR4	\$ 29340.	ESR4	\$ 40248.	EWR4	\$ 42408.	EAR4	\$ 47340.
	110 (2-55)	4	5	FOR4	34704.	FSR4	45612.	FWR4	47772.	FAR4	52704.
	220 (2-110)	5	5	GOR4	47304.	GSR4	59562.	GWR4	61722.	GAR4	68004.
	300 (2-150)	5A †	5 ■	GAOR4	54399.	GASR4	68496.	GAWR4	70980.	GAAR4	78204.
	450 (2-225)	6	6	HOR4	77760.	HSR4	94068.	HWR4	96228.	HAR4	106560.

▲ Non-ventilated NEMA Type 12 enclosures are not recommended for CMAA Service Classifications E and F and for applications which have frequent jogging and inching operations because a corrosive atmosphere, detrimental to the component parts, can develop. For these applications, NEMA 1 Gasketed enclosures are recommended.

★ For explanation and pricing of multi-motor controls refer to multi-motor drives section of application data.

† Not a NEMA Size/Rating.

■ NEMA standards require 6 speed points above 110HP. Add 1 speed point if required.

● For higher horsepower, consult factory.

#### Ordering Information Required:

1. Class
2. Type
3. Motor Horsepower at 230 VDC
4. Motor Duty Rating
5. Controller Modifications:  
Specify Form Numbers
6. Resistor Service Classification
7. Master Switch Class, Type and Form

CP9A  Discount Schedule



# Crane Control Class 6121 Pricing Information and Application Data

**CRANE CONTROL  
CLASS 6121**

## BRIDGE OR TROLLEY SERVICE

A complete set of motor control equipment consists of a controller, separately mounted Tab-Weld® resistors, and a master switch. The following tables are for selecting the resistors and master switches used with Class 6121 Bridge or Trolley controllers.



**Class 6715  
Tab-Weld® Resistor**



**Class 9004  
Type CG12  
Master Switch**



**Class 9004  
Type VG12  
Master Switch**

**Tab-Weld® Resistor Selection Table** ★ †

Maximum HP Rating Single Motor ■	Price		Price Additions
	Without Armature Shunt		Continuous Duty Slowdown Resistor ▲
	NEMA Class ●		
	162-P	172-P	
5	\$ 954.	\$ 954.	\$ 870.
7-1/2	954.	954.	990.
10	954.	1280.	1110.
15	1268.	1280.	1350.
20	1268.	1374.	1920.
25	1268.	1638.	2265.
30	1962.	2844.	3690.
35	2223.	3222.	4005.
40	2475.	3591.	4455.
45	2763.	4005.	4905.
50	2970.	4311.	5400.
60	3591.	5211.	5895.
65	3861.	5598.	6840.
70	4158.	6030.	9675.
75	4392.	6372.	10215.
90	5238.	7596.	11565.
100	5769.	8361.	12060.
135	7704.	11169.	...
150	8514.	12348.	...
200	11250.	16317.	...

- ★ It is recommended that bridge or trolley resistors be selected based on the 1 hour motor horsepower rating unless specified otherwise.
- † For resistors mounted in racks, refer to Class 6715.
- Duplex controllers require two sets of resistors, one set for each motor.
- Class 162 is recommended for standard crane duty.  
Class 172 is recommended for severe crane duty.  
For explanation of NEMA Resistor Classifications, refer to Class 6715 Application Data.  
Consult factory for other NEMA Classes.
- ▲ Slowdown resistors are designed to limit Bridge drives to approximately 50% of their present free running speed. Complete motor nameplate data plus the free running current drawn by the motor must be provided to design the slowdown resistors.

**Master Switch Selection Table**

Class 9004 VM or CM NEMA 1 Enclosed						
Drive	Speed Points	Control Type	VM		CM	
			Type	Price	Type	Price
Bridge or Trolley	5	U	VG9	\$ 2379.	CG8	\$ 2730.
	6	U	VG9	2379.	...	...
	6v	U	...	...	CG12	3213.

### Modifications

Description	Optional Feature Form Letter	Price Addition	
		VM	CM
Spring Return to Off Point	S	\$ 444.	\$ 444.

### Accessories

- Brakes ..... see Class 5010 or 5015
- Adjustable Torque Brakes ..... see Class 5060
- Manual-Magnetic Disconnect Switch ..... see Class 6140

CP9A  Discount Schedule



# Crane Control Class 6121

## Pricing Information and Application Data

### Controller Modifications

Form	Description	Price ■						
		Maximum HP Rating — Single Motor						
		35	55	110	150	225	275	500
B1 ▲	Shunt Brake Relay	\$ 1656.	\$ 1656.	\$ 1656.	\$ 1656.	\$ 1656.	...	...
B3 ▲	Shunt Brake Relay	1656.	1656.	1656.	1656.	1656.	...	...
B4 ▲	Shunt Brake Relay	1656.	1656.	1656.	...	...	...	...
B9 ▲●	Service Dynamic Braking	◆	◆	◆	◆	◆	◆	◆
B10 ▲●	Emergency Dynamic Braking, Single Point	◆	◆	◆	◆	◆	◆	◆
B11 ▲●	Emergency Dynamic Braking, Auto Deceleration							
D1	Substitute Main Line Knife Switch with DC Rated Fuses for Unused Main Line Knife Switch	2820.	3278.	3773.	4088.	5963.	6660.	◆
D7 ★	Series Brake Transfer Knife Switches	3204.	5202.	7344.	7347.	13536.	14768.	16896.
E19	Low Headroom	◆	◆	◆	◆	...	...	...
G8	Power Terminal Board (Includes Power Lugs)	◆	◆	◆	◆	◆	◆	◆
G15	Ammeter Shunt, 100MV	468.	630.	1512.	1613.	2430.	2430.	3564.
G16	Miniature Ammeter Panel Mounted	450.	450.	450.	450.	450.	450.	450.
G22	Cabinet Inspection Light and Toggle Switch	1125.	1125.	1125.	1125.	1125.	1125.	1125.
H18	Cabinet Space Heater Controlled by Interlock from M Contactor	990.	990.	990.	990.	990.	990.	990.
M3 †	Additional Acceleration Point	1746.	2052.	2736.	3072.	4167.	4860.	8154.
M4	Second Plugging Step	2196.	2502.	3186.	3522.	4617.	...	...
M24	Substitute Type SSI Time Current Acceleration Module for Type ST-1 Static Acceleration Timers	1575.	1575.	1575.	1575.	1575.	1575.	1575.
M52 ▲●	Armature Shunt Contactor (Controls Slowdown for Floor/Cab Operation)	1053.	1359.	2043.	2343.	3474.	...	...
R1 □	Auto-Stop Rectifier Circuit	1245.	1245.	1410.	1410.	1868.	1868.	1868.
Y17	Arc Suppressors (Required on Pendant and Radio Operated Controllers)	1620.	1620.	1620.	1620.	1620.	1620.	1620.

- For Duplex Controllers multiply all prices by two with the exceptions of forms, D7, B10, B11.
- ★ For Duplex Controllers using Series Brakes.
- Does not include resistor prices.
- ▲ For Bridge and Trolley controllers only. See Application Data for explanation of form number.
- For Hoist Controllers only. See Application Data for explanation of form number.
- † Additional master switch contacts will be required. See Catalog 9004 for correct master switch and price.
- ◆ Consult factory for price and delivery.

### Application Data

#### Multi-Motor Drives

**Two motors connected in series** – The armatures and fields of each motor are connected in series and treated as a single motor. If the voltage rating of each motor is 230 VDC and the supply voltage is 230 VDC, the horsepower rating is equal to the rating of one motor. If the voltage rating of each motor is 115 VDC and the supply voltage is 230 VDC, the horsepower rating is equal to the sum of the ratings of both motors. Controller and resistor pricing is based on the horsepower rating. A single set of motor power resistors is required.

**Two motors connected in parallel (Duplex)** – One set of control equipment and power resistors is required for each motor. Controller modification prices are double those shown for a single motor scheme.

**Four motors connected in parallel (Quadruplex)** – It is necessary to double the duplex controller price given for two motors in parallel. Four sets of motor power resistors are required.

**Four motors connected in series-parallel** – Two sets of series motors with their armatures and fields connected in series are connected in parallel. Controllers and modifications for this connection should be priced based on two motors in parallel. Two sets of motor power resistors are required.

CP9A		Discount Schedule
------	--	-------------------



### Special Panel Construction

Several types of factory assembled and unitized constructions are available. Consult factory for price and delivery.

Standard controllers come equipped with the components listed. Special features to be added to standard controllers are identified by Form number. Most of these modifications are self-explanatory. Others, however, require some additional explanation.

Forms B1, B3, and B4 cover various shunt brake relay applications. These modifications are for Bridge and Trolley controllers only and in each case a double-pole, 25-ampere brake relay is supplied. The three modifications differ from each other in the way the relay is wired and controlled. Each is as follows:

**B1:** Relay connected in parallel with main (M) contactor coil. With this arrangement, the shunt brake will set whenever the master switch is moved to the off point.

**B3:** Relay controlled from external push button, foot switch, etc. This arrangement allows the shunt brake to be manually applied by the crane operator whenever necessary.

**B4:** Relay connected in parallel with undervoltage relay. The arrangement allows the shunt brake to set only when the main disconnect for the crane is opened or upon power failure.

**Form B9**, Service dynamic braking, is used for decelerating travel drives under normal operation. Service dynamic braking is occasionally used in place of plugging on a travel drive. The common arrangement is to use an initiating switch in conjunction with the electric adjustable torque or hydraulic brake pedal such that initial depression of the brake pedal provides service dynamic braking and further depression actuates the adjustable torque or hydraulic brake. Service dynamic braking assists the adjustable torque or hydraulic brake.

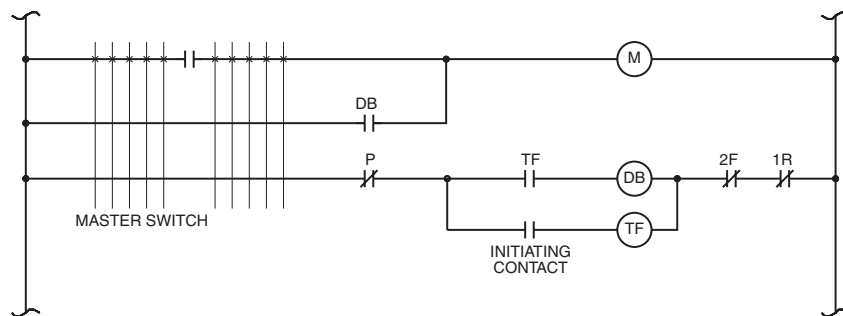
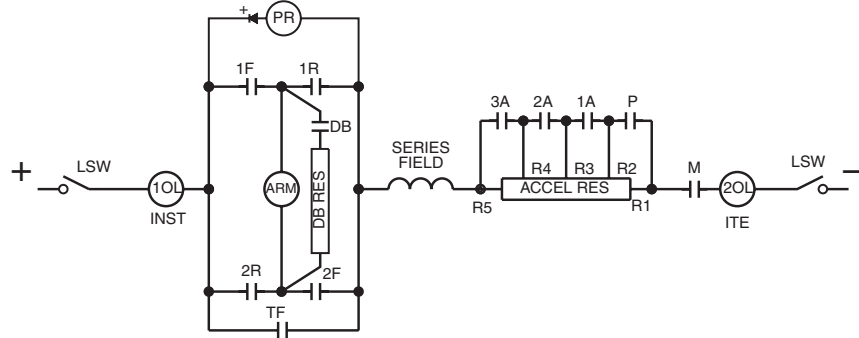

**Service Dynamic Braking for Single Series Motor**

**Form B10** covers emergency dynamic braking. Emergency dynamic braking is used to decelerate crane travel drives, such as high speed bridge drives and manned trolleys and is automatically applied upon power failure or when an overload relay trips. Emergency dynamic braking provides a simple, reliable means for braking to a stop bridge drives of cranes, or manned trolleys of ore and coal bridges, etc. Emergency dynamic braking is applied in about 1/5 the time required to set a shunt brake. The motors are converted to self-excited generators to provide retarding torque. Braking is not dependent on an outside source of power. The circuits for single step emergency dynamic braking are shown for the various motor connections.

## Crane Control Class 6121 Controller Modifications

**Emergency Dynamic Braking For A Single Motor** – The motor is connected as self-excited generator by using a silicon rectifier bridge around the motor series field. Braking is equally effective in each direction.

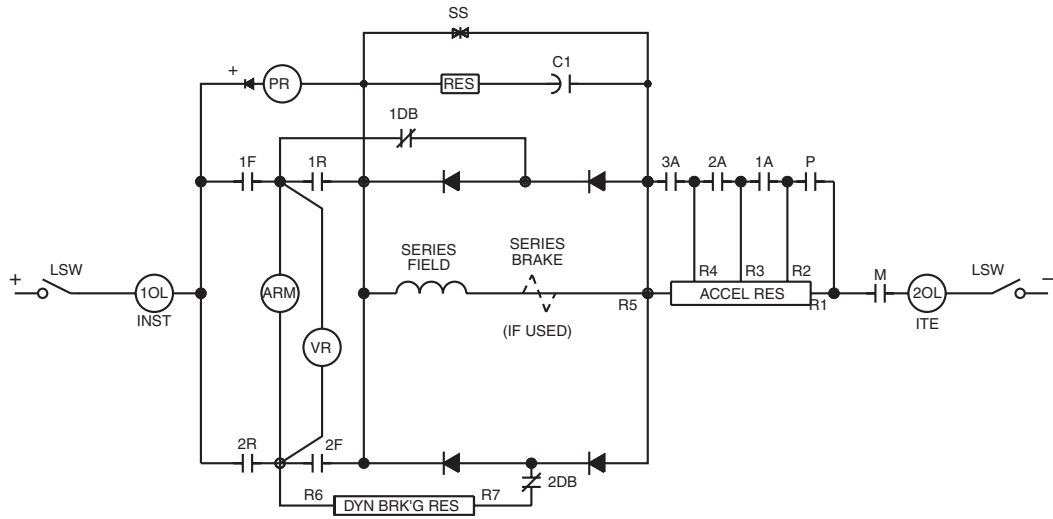

**Emergency Dynamic Braking for Single Motor**

**Emergency Dynamic Braking For Two Motors Connected In Series** – The same circuit as for a single motor is used. The armatures and fields of the two motors are permanently connected in series and are treated as a single motor.

**Emergency Dynamic Braking For Two Motors Connected In Parallel** – The circuit shows the simple arrangement whereby the fields and the armatures of the two series motors are cross-connected to insure self-excitation for positive emergency dynamic braking from either direction of travel. Two sets of double-pole dynamic braking contactors are used.

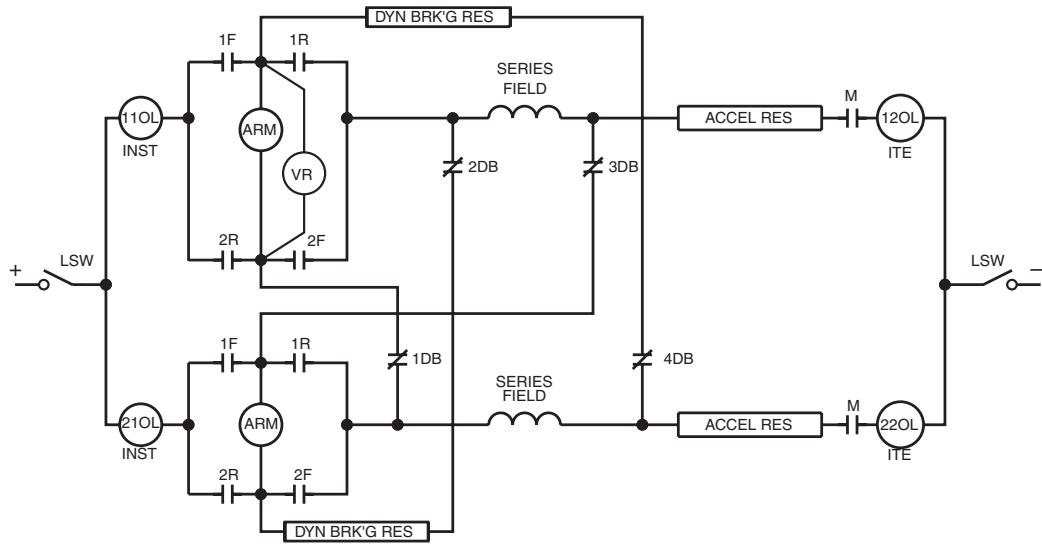

**Emergency Dynamic Braking for 2 Motors in Parallel**



**Emergency Dynamic Braking For Four Motor Drives** – For four motors connected in parallel, two sets of cross-connected motors are connected in parallel to provide dynamic braking for all four motors. For this motor connection, the controller modification is priced by doubling the price given for two motors in parallel.

When four motors are connected in series parallel, that is, when two sets of motors with their armatures and fields connected in series are connected in parallel, emergency dynamic braking should be priced based on the controller modification for two motors connected in parallel.

**Form B11** covers graduated emergency dynamic braking with automatic deceleration. The automatic deceleration provides a faster stop than single step deceleration from high speed without wheel slippage.

**Graduated Emergency Dynamic Braking with Automatic Deceleration for a Single Motor** – An additional voltage relay (2VR) and a spring closed contactor (3DB) with its main contacts shorting out a portion of the dynamic braking resistor are added to the circuit for single step emergency dynamic braking. The two voltage relays (1VR and 2VR) are used to insure proper operation of the 3DB contactor. The generated armature voltage keeps the 3DB contactor energized until the motor speed is decreased sufficiently to provide a smooth deceleration. When the 3DB contactor closes, the value of the dynamic braking resistance is decreased, and increased braking torque is provided to stop the drive.

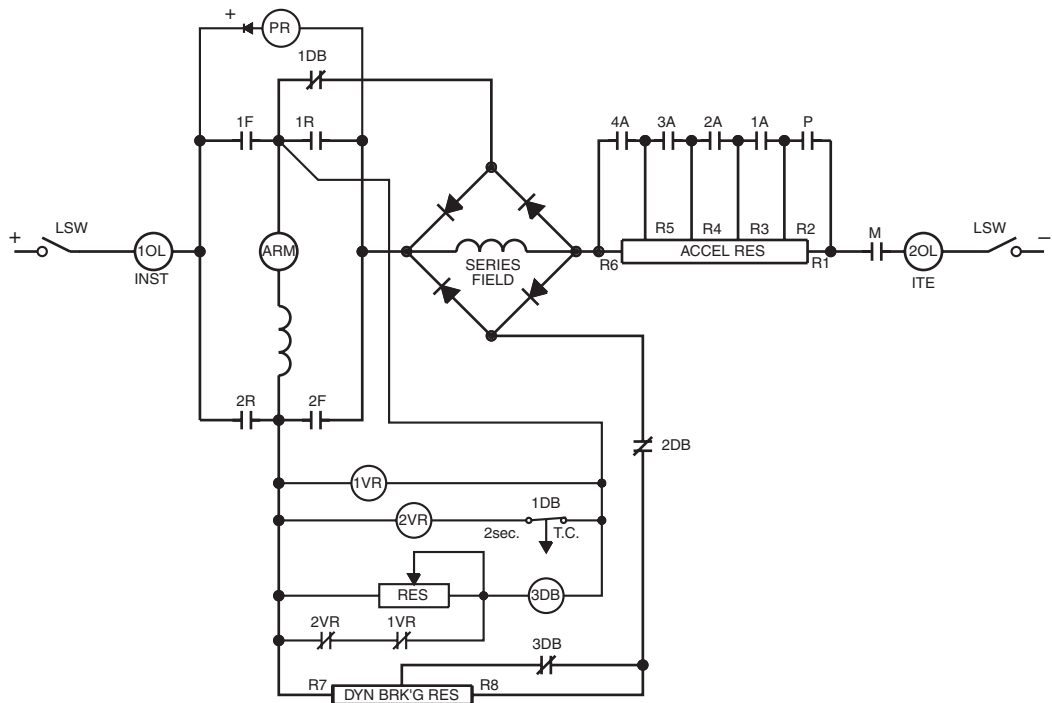

**Graduated Emergency Dynamic Braking with Automatic Deceleration for a Single Motor.**

## Crane Control Class 6121 Controller Modifications

**Graduated Emergency Dynamic Braking with Automatic Deceleration for Multi-Motor Drives**—For two motors connected in series, the fields of each motor are connected in series inside the rectifier bridge and are treated as a single motor.

The circuit for two motors connected in parallel is essentially the same as that for two motors in parallel with single step dynamic braking except for the addition of two voltage relays, 1VR and 2VR, and two normally closed contactors, 5DB and 6DB. The voltage relays and the normally closed contactors are operated based on the generated armature voltage of one motor, but control the braking of both motors. The two contactors are adjusted to reclose together as the motors decelerate. This reclosure shorts out part of the dynamic braking resistor, maintaining deceleration torque.

For Quadruplex connections where four motors are connected in parallel, it is necessary to double the controller modification price shown for two motors in parallel.

For four motors used in a series-parallel connection, graduated emergency dynamic braking should be priced based on the controller modification price for two motors connected in parallel.

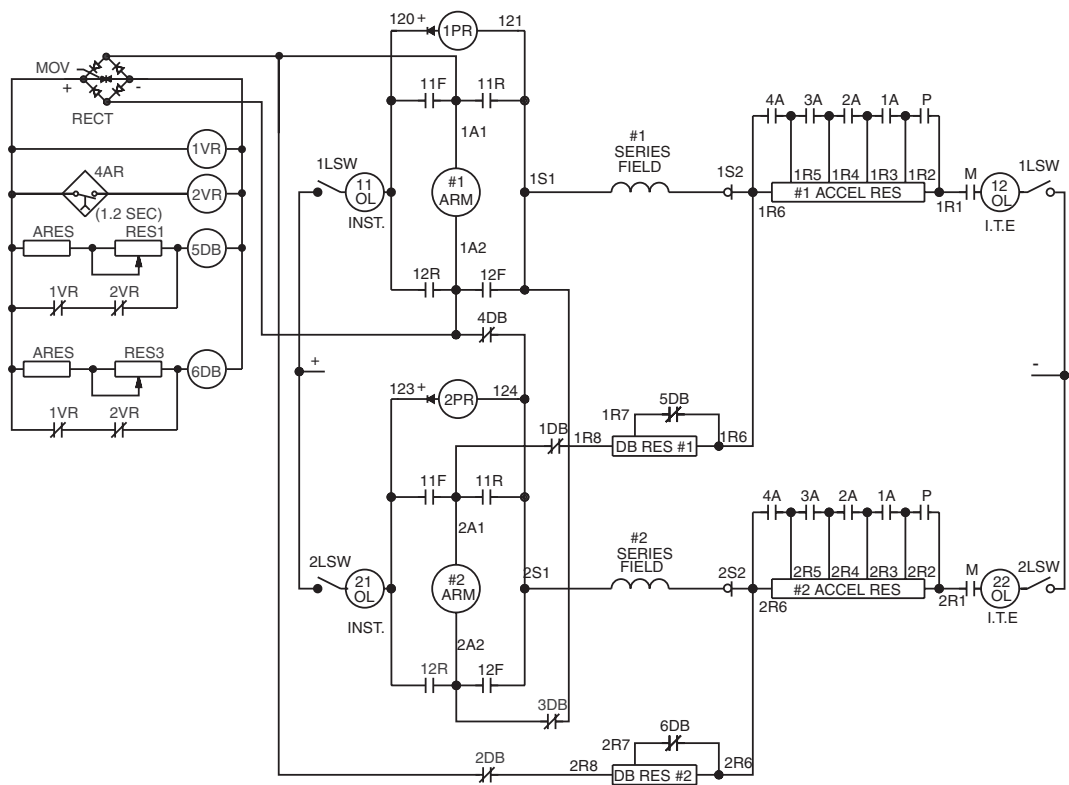

**Graduated Emergency Dynamic Braking for Two Motors in Parallel**

**Form D7** lists series brake transfer knife switches for use on duplex controllers. For single motor operation, these knife switches connect both series brakes in series with one motor to permit operating the drive without having to manually release one brake.

**Form M4** lists a second plugging step. An additional plugging relay (2PR) and an additional plugging contactor (2P) are supplied. A second plugging step is recommended for heavy cranes, such as ladle crane bridge drives or high speed cranes such as ore bridge trolleys or high speed bridge drives. Two steps of plugging provide faster slowdown without spinning the wheels.

**Form M24** provides time delay acceleration proportional to motor current.

# Crane Control Class 6121 Application Data

CRANE CONTROL CLASS 6121

**Form M52** is an armature shunt contactor for use on Bridge and Trolley controllers only. This modification consists of a single pole normally open contactor of equal NEMA Size to the contactors in the basic controller. The operation is as follows:

The contactor is arranged to provide slowdown of bridge drives during floor operation of cab/floor operated cranes. A customer supplied contact, maintained closed during floor operation, initiates the slowdown. This modification is to be used with NEMA Class 162P or Class 172P accelerating resistors plus a continuous duty bridge slowdown resistor.

**Form R1** Auto-Stop Rectifier circuit is used on hoist applications. The series DC brake is set by returning the master switch to the off position during normal running conditions. In a power failure situation the brake will set if the controller is in hoist mode. If however, the standard controller is in lower mode, regenerative power from the DC motor will keep the series brake open and allow the load to be safely lowered. With the Auto-Stop Rectifier circuit modification, the series brake will work as usual in normal running conditions. In a power failure situation, the brake will automatically set in both hoist and lowering modes.

**Crane Hook Speed vs. Load Performance for Class 6121 Dynamic Lowering Hoist**

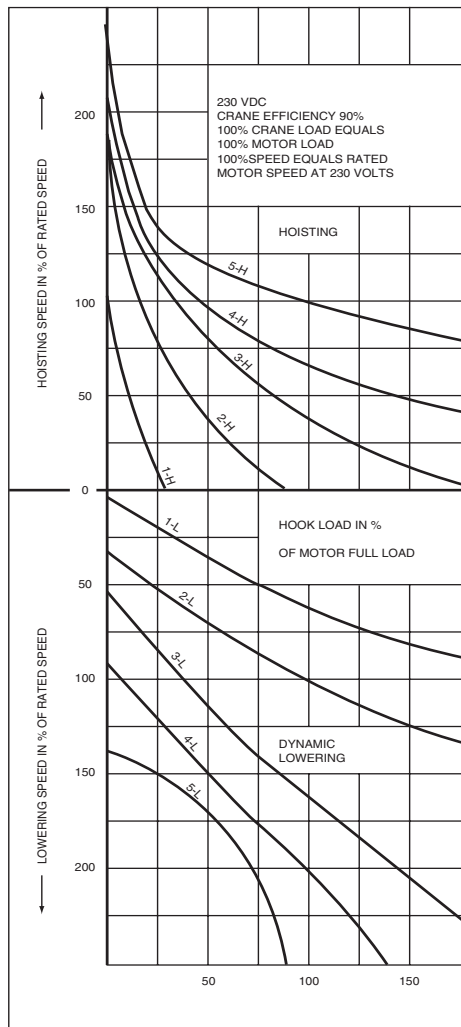

**Crane Travel Speed vs. Load Performance for Class 6121 Reversing Plugging**

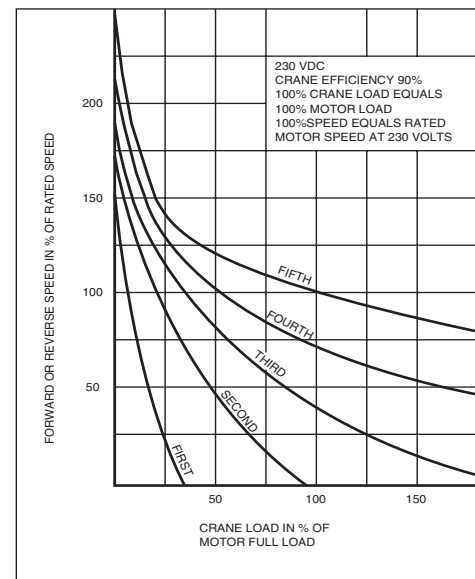



## ELEMENTARY WIRING DIAGRAM FOR BRIDGE OR TROLLEY CONTROL

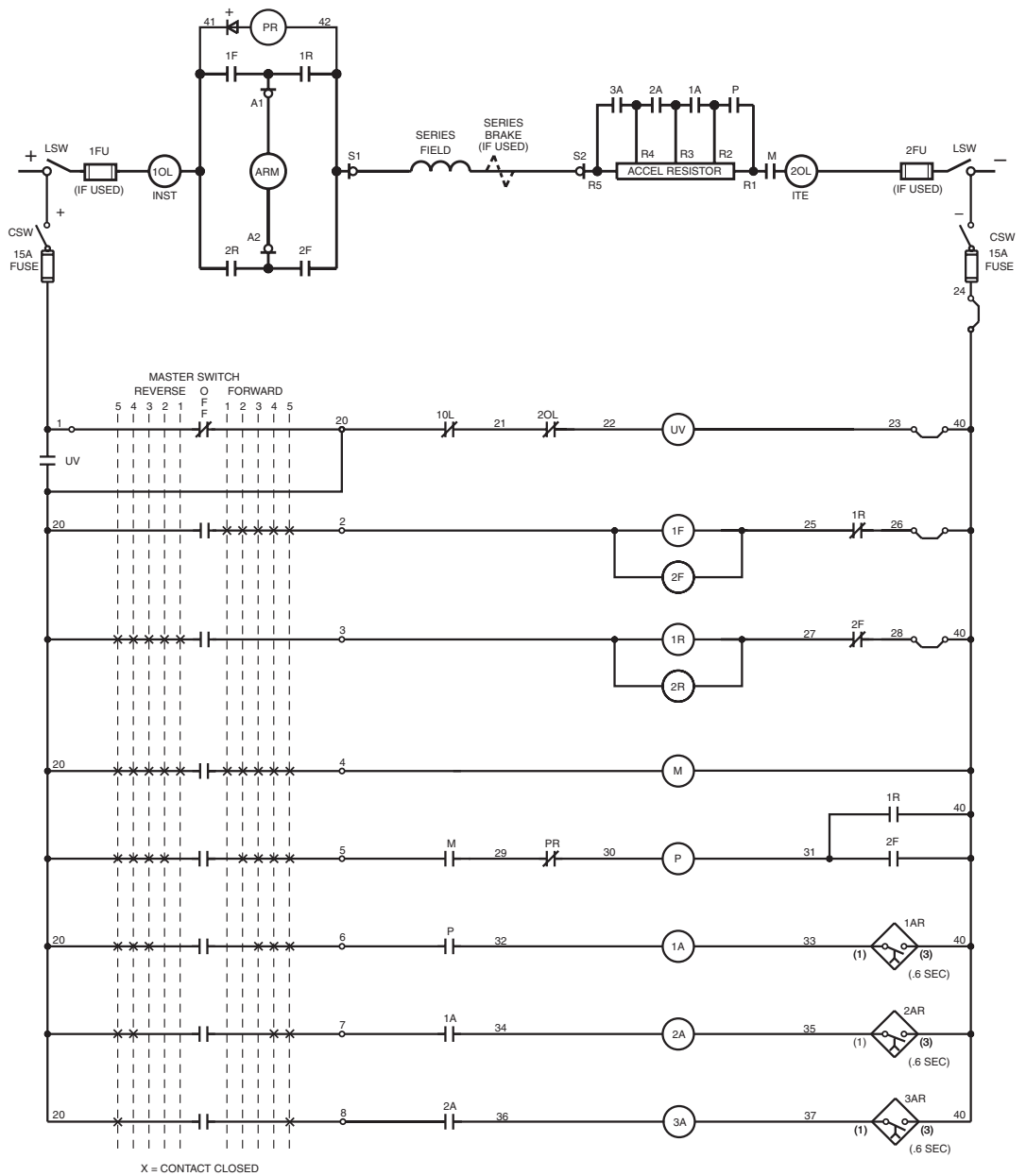

X = CONTACT CLOSED

CONTACTOR SEQUENCE		REVERSE					O	FORWARD				
DEVICE		5	4	3	2	1		1	2	3	4	5
1F								X	X	X	X	X
2F								X	X	X	X	X
1R		X	X	X	X	X						
2R		X	X	X	X	X						
M		X	X	X	X	X		X	X	X	X	X
P		X	X	X	X	X		X	X	X	X	X
1A		X	X	X	X	X						
2A		X	X	X	X	X						
3A		X	X	X	X	X						

CONTACTORS 1R & 1F, 1F & 2R, 2R & 2F  
ARE MECHANICALLY INTERLOCKED.



# Crane Control Class 6121

## Application Data

CRANE CONTROL CLASS 6121

### APPROXIMATE NUMBER OF SEPARATELY MOUNTED STANDARD CLASS 6715 TAB-WELD® RESISTOR SECTIONS FURNISHED WITH CLASS 6121 CONTROLLERS

This tabulation is based on Square D resistor designs for use with Class 6121 controllers only. This tabulation is for typical drive loading and may vary for any specific application.

Maximum HP Rating Single Motor (230V)	Hoist ▲			Bridge Or Trolley		
	162-DL	172-DL	Teaser Field	Without Armature Shunt		Continuous Duty Slowdown Resistor ●
				162-P	172-P	
5	5	5	3	1	1	1
7-1/2	4	4	2	1	1	1
10	3	3	2	1	2	1
15	3	3	1	2	2	2
20	3	4	1	2	3	3
25	4	6	1	2	3	4
30	5	7	1	3	3	4
35	6	8	1	3	4	5
40	6	10	1	3	4	5
45	8	11	2	4	5	6
50	8	11	2	4	6	6
60	10	15	2	4	6	7
65	11	15	2	4	6	8
70	11	14	2	5	7	11
75	11	17	2	6	7	11
90	13	17	2	6	9	13
100	16	19	2	6	9	13
135	20	30	4	9	12	...
150	21	28	4	10	12	...
200	28	38	5	13	19	...
250	34	44	7	16	21	...
275	43	53	8	18	24	...
300	43	53	8	19	26	...
325	43	56	8	20	28	...
375	48	62	8	23	32	...
500	75	97	14	32	44	...

- ▲ Does not include YOUNGSTOWN® power limit switch resistor. Refer to Class 6170.
- Does not include acceleration resistor.

### Standard Class 6715 Tab-Weld® Resistor Section

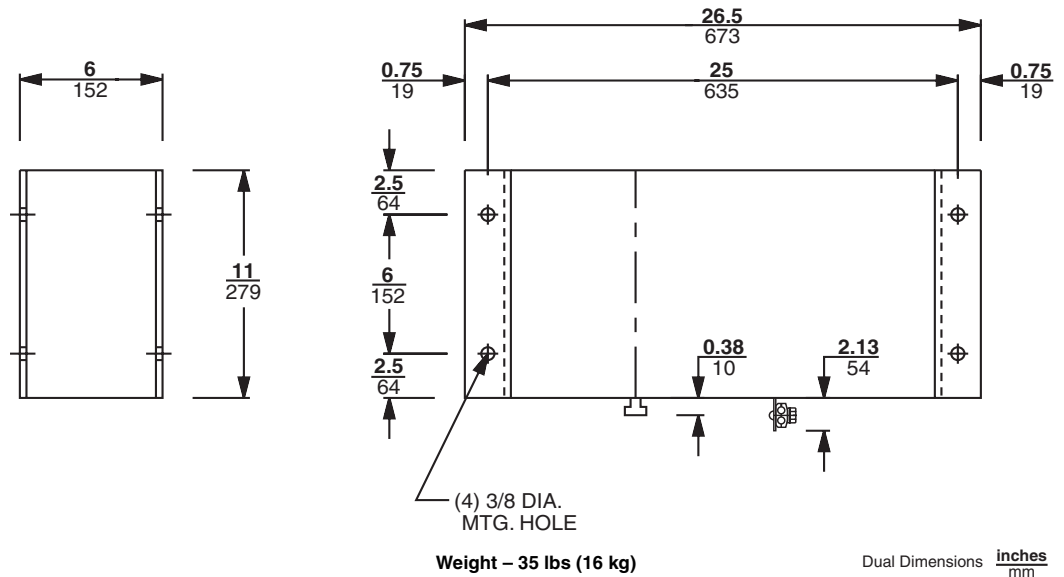

**INCREASE IN STANDARD PANEL WIDTH FOR COMMONLY USED MODIFICATIONS**

The table below may be used to determine what increase in width in inches (mm), if any, results when modifications are added to a standard Class 6121 controller. The dimensions apply only to individual modifications or combination of modifications for which they are shown.

**Controller Modifications**

Form	Description		Maximum HP Crane Rating per Motor (230V)					
			35	55	110	225	275	500
B1 ●	Shunt brake relay		0	0	0	0	...	...
B3 ●	Shunt brake relay		0	0	0	0	...	...
B4 ●	Shunt brake relay		0	0	0	0	...	...
B9 ●	Service dynamic braking		▲	▲	▲	▲	...	...
B10 ●	Emergency dynamic braking, single point	Single motor Two motors in parallel Two motors in series	▲	▲	▲	▲	...	...
B11 ●	Emergency dynamic braking, auto deceleration							
D1	Substitute fused main line knife switch for unfused main line knife switch		0	0	0	0	...	▲
G15	Ammeter shunt, 100MV		0	0	0	0	0	0
G16	Miniature ammeter, panel mounted		0	0	0	0	0	0
H18	Cabinet space heater		0	0	0	0	0	0
M3	Additional acceleration point (hoist)		6 (152)	6 (152)	7 (178)	0	9 (229)	21 (533)
M3 ●	Additional acceleration point (bridge or trolley)		0	0	0	0	...	...
M4 ●	Second plugging step		0	0	0	0	...	...
M24	Type SSI time current acceleration module instead of Type ST static timers		0	0	0	0	0	0
M52 ●	Armature shunt contactor (Controls slowdown for floor/cab operation)		0	0	0	0	...	...
R1 ◆	Auto-Stop Rectifier circuit		6 (152)	6 (152)	7 (178)	0	9 (229)	21 (533)
Y17	Arc suppressors (Required on pendant and radio operated controllers)		0	0	0	0	0	0

- For bridge & trolley controllers only.
- ▲ Consult factory.
- ◆ For hoist controllers only.



# Crane Control Class 6121

## Approximate Dimensions and Weights

CRANE CONTROL CLASS 6121

### SINGLE MOTOR CONTROL STANDARD FLOOR MOUNTED CONTROLLERS

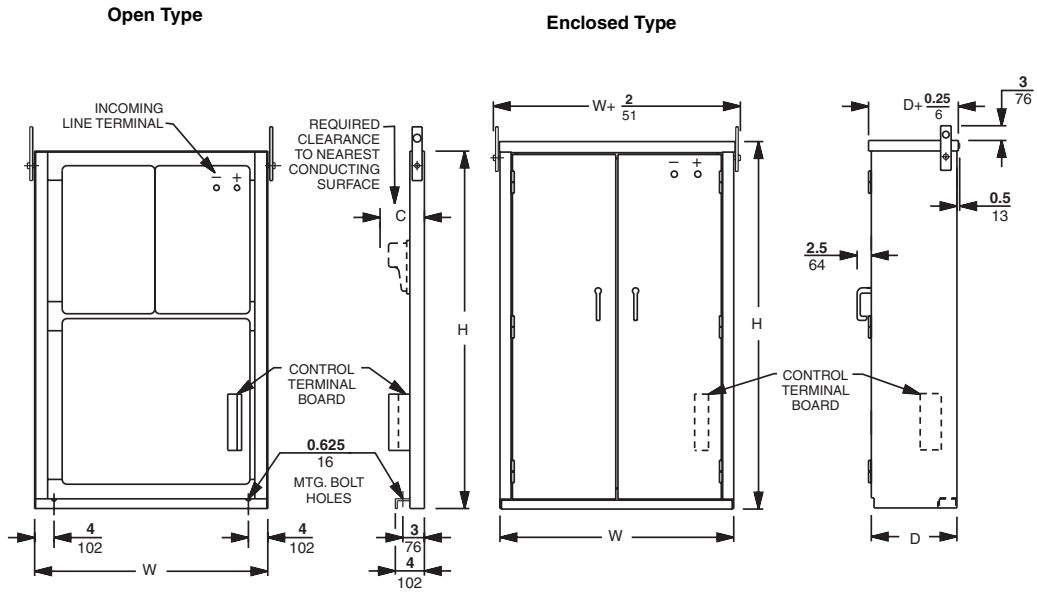

Dual Dimensions  $\frac{\text{inches}}{\text{mm}}$

Drive	Maximum HP (230V)	Open Type				Enclosed Type			
		H	W	C	Net Weight lbs (kg)	H	W	D	Net Weight lbs (kg)
Hoist	35	$\frac{68}{1727}$	$\frac{33}{838}$	$\frac{12}{305}$	500 (227.3)	$\frac{68}{1727}$	$\frac{33}{838}$	$\frac{15}{381}$	700 (318.2)
	55	$\frac{68}{1727}$	$\frac{33}{838}$	$\frac{12}{305}$	500 (227.3)	$\frac{68}{1727}$	$\frac{33}{838}$	$\frac{15}{381}$	700 (318.2)
	150 ▲	$\frac{78}{1981}$	$\frac{38}{965}$	$\frac{15}{381}$	700 (318.2)	$\frac{78}{1981}$	$\frac{38}{965}$	$\frac{17}{432}$	900 (409.1)
	275	$\frac{72}{1829}$	$\frac{72}{1829}$	$\frac{21}{533}$	1300 (590.9)	$\frac{72}{1829}$	$\frac{72}{1829}$	$\frac{23}{584}$	1800 (818.2)
	500	$\frac{90}{2286}$	$\frac{99}{2515}$	$\frac{25}{635}$	2600 (1181.8)	$\frac{90}{2286}$	$\frac{99}{2515}$	$\frac{27}{686}$	3700 (1681.8)
Bridge or Trolley	35	$\frac{68}{1727}$	$\frac{33}{838}$	$\frac{12}{305}$	500 (227.3)	$\frac{68}{1727}$	$\frac{33}{838}$	$\frac{15}{381}$	700 (318.2)
	55	$\frac{68}{1727}$	$\frac{33}{838}$	$\frac{12}{305}$	500 (227.3)	$\frac{68}{1727}$	$\frac{33}{838}$	$\frac{15}{381}$	700 (318.2)
	150 ▲	$\frac{78}{1981}$	$\frac{38}{965}$	$\frac{15}{381}$	700 (318.2)	$\frac{78}{1981}$	$\frac{38}{965}$	$\frac{17}{432}$	900 (409.1)
	225	$\frac{72}{1829}$	$\frac{72}{1829}$	$\frac{21}{533}$	1200 (545.5)	$\frac{72}{1829}$	$\frac{72}{1829}$	$\frac{23}{584}$	1500 (681.8)

▲ Dimensions are for a 5 speed point controller. NEMA standards require 6 speeds above 110HP. Refer to Form M3 for increase in panel width.





# Crane Control Class 6121 Approximate Dimensions and Weights

## DUPLEX MOTOR CONTROL STANDARD FLOOR MOUNTED CONTROLLERS

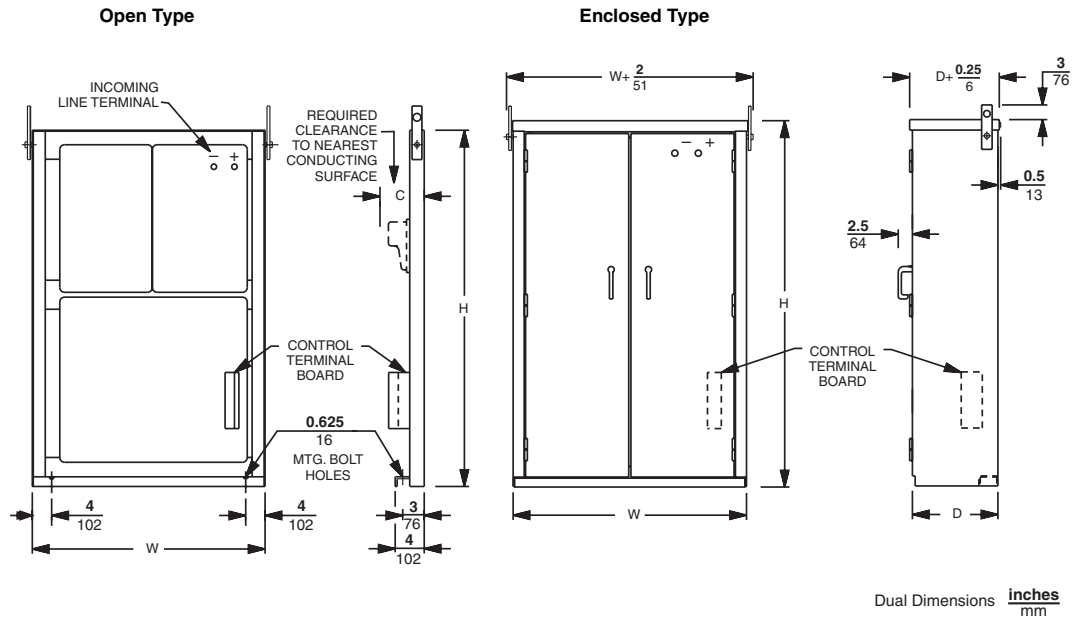

CRANE CONTROL CLASS 6121

Drive	Maximum HP (230V)	Open Type				Enclosed Type			
		H	W	C	Net Weight lbs (kg)	H	W	D	Net Weight lbs (kg)
Hoist	70 (2-35)	<u>68</u> 1727	<u>66</u> 1676	<u>12</u> 305	1000 (453.6)	<u>68</u> 1727	<u>66</u> 1676	<u>15</u> 381	1000 (453.6)
	110 (2-55)	<u>68</u> 1727	<u>66</u> 1676	<u>12</u> 305	1000 (453.6)	<u>68</u> 1727	<u>66</u> 1676	<u>15</u> 381	1000 (453.6)
	220 (2-110)	<u>78</u> 1981	<u>77</u> 1956	<u>15</u> 381	1400 (635.0)	<u>78</u> 1981	<u>77</u> 1956	<u>17</u> 432	1800 (818.2)
	300 (2-150) ♦	<u>78</u> 1981	<u>56/45</u> 1422/1143	<u>15</u> 381	1100 (500.0)	<u>78</u> 1981	<u>56/45</u> 1422/1143	<u>17</u> 432	1420 (645.5)
	450 (2-225) ♦	<u>72</u> 1829	<u>72/78</u> 1829/1981	<u>21</u> 533	1300 (590.9)	<u>72</u> 1829	<u>72/78</u> 1829/1981	<u>23</u> 584	1800 (818.2)
	550 (2-275) ♦	<u>72</u> 1829	<u>72/78</u> 1829/1981	<u>21</u> 533	1300 (590.9)	<u>72</u> 1829	<u>72/78</u> 1829/1981	<u>23</u> 584	1800 (818.2)
	1000 (2-500) ♦	<u>90</u> 2286	<u>99</u> 2515	<u>25</u> 635	2600 (1181.8)	<u>90</u> 2286	<u>99</u> 2515	<u>27</u> 686	3700 (1681.8)
Bridge or Trolley	70 (2-35)	<u>68</u> 1727	<u>66</u> 1676	<u>12</u> 305	1000 (453.6)	<u>68</u> 1727	<u>66</u> 1676	<u>15</u> 381	1400 (635.0)
	110 (2-55)	<u>68</u> 1727	<u>66</u> 1676	<u>12</u> 305	1000 (453.6)	<u>68</u> 1727	<u>66</u> 1676	<u>15</u> 381	1400 (635.0)
	300 (2-150)	<u>78</u> 1981	<u>77</u> 1956	<u>15</u> 381	1400 (635.0)	<u>78</u> 1981	<u>77</u> 1956	<u>17</u> 432	1800 (818.2)
	450 (2-225) ♦	<u>72</u> 1829	<u>72</u> 1829	<u>21</u> 533	1200 (545.5)	<u>72</u> 1829	<u>72</u> 1829	<u>23</u> 584	1800 (818.2)

- ♦ Two control panels are required. Dimensions are given for each except:
  - The Size 5A hoist, which has one panel 56" (1422 mm) wide and the second at 45" (1143 mm) wide.
  - The Size 6 and 6A hoists, which have one panel 72" (1829 mm) wide, and one at 78" (1981 mm) wide.



# Crane Control Class 6121

## Rectified DC Constant Potential HWR Hoist Control

### GENERAL INFORMATION AND PRICING

HWR hoist control is recommended for use with DC series motors on AC powered cranes requiring the speed range, accuracy and dependability of a DC powered crane hoist controller. Typically, 230 VDC rated motors are applied at either 230 VDC, 300 VDC, or 360 VDC.

The complete HWR Hoist Control system consists of:

- 1 Class 6121 DC reversing dynamic lowering controller
- 1 Set of Class 6715 Tab-Weld® resistors
- 1 Class 9004 Master switch
- 1 Rectifier power supply

Consult factory for price and delivery.

**Tab-Weld® Resistor Selection Table ▲**

Maximum HP Crane Rating @230 VDC	NEMA Class ●	
	162-DL ★	172-DL ★
5	\$ 5679.	\$ 7956.
7-1/2	4779.	6696.
10	4779.	6696.
15	4572.	6399.
20	5409.	7578.
25	6237.	8730.
30	7152.	9927.
35	8001.	11196.
40	8829.	12366.
45	10314.	14436.
50	11196.	15678.
60	12861.	18009.
65	13788.	19143.
70	14940.	20916.
75	15831.	22167.
90	18378.	25731.
100	20142.	28197.
135	27360.	38304.
150	29925.	41895.
200	39366.	55116.
250	50553.	70776.
275	55566.	77796.
300	59850.	83790.
325	64872.	90819.
375	73521.	102933.

- ▲ For resistors mounted in racks - refer to Class 6715.
- Class 162 is recommended for standard crane duty. Class 172 is recommended for severe crane duty. For explanation of NEMA Resistor Classifications- refer to Class 6715 Application Data.
- ★ Resistor pricing based on 300 VDC rectifier output. For 360 VDC applications, consult factory.

CP9A  Discount Schedule



# Crane Control Class 6121 Rectified DC Constant Potential HWR Hoist Control

**CRANE CONTROL  
CLASS 6121**

## APPLICATION DATA

### Comparison of Basic Characteristics of DC Series Motors and AC Wound Rotor Motors

DC Series Motor	AC Wound Rotor Motor
<ul style="list-style-type: none"> <li>- No Load speed is approximately two or three times full load speed.</li> <li>- When used with a dynamic lowering controller the motor can lower rated load at a speed much greater than the rated load hoisting speed.</li> </ul>	<ul style="list-style-type: none"> <li>- Maximum motor speed limited to near synchronous speed for no load and full load.</li> </ul>
<ul style="list-style-type: none"> <li>- Maximum motor speed increases in proportion to increase in line voltage.</li> <li>- Increased speeds result in increased horsepower without change in motor size.</li> </ul>	<ul style="list-style-type: none"> <li>- Maximum motor speed not affected by increase in line voltage.</li> </ul>

HWR hoist control features a rectifier supplying 300 VDC power to a Class 6121 DC dynamic lowering hoist controller and a standard 230 VDC series wound crane hoist motor and series brake.

The 300 VDC output from the rectifier increases the developed horsepower of a 230 VDC series wound motor by 30%. Inherently, a DC series wound motor increases its hoisting speed as the load is decreased; and with a dynamic lowering controller, has the ability to safely lower loads at greater than full load speed. As a result of the increase in developed horsepower and these inherent performance characteristics, a given hoisting cycle can be completed in the same average time by using a 230 VDC series wound motor having a horsepower rating between 50% to 65% of its AC counterpart.

Even greater performance can be obtained by increasing the voltage to the motor to 360 VDC.

### Performance Comparison ▲

Control Type	Standard AC	Standard 230 VDC	Standard HWR 300 VDC	Optional HWR 360VDC
Hoist Full Load	96%	100%	125%	155%
Lower Full Load	102%	230%	235%	240%
Hoist Empty Hook	99%	180%	250%	280%
Lower Empty Hook	100%	140%	175%	215%
Average	99%	148%	182%	212%

▲ 100% speed = AC motor synchronous speed or DC rated speed at 230 VDC. A 90% efficiency is assumed.

### Number of Separately Mounted Standard Class 6715 Tab-Weld® Resistor Sections 26.5" (673 mm) Long ▲

Horsepower @ 230 VDC	10	13-1/2	19	26	33	45	65	100	135	200	265	360
<b>NEMA Class 162-DL</b>	5	5	6	8	10	12	17	21	30	43	53	68
<b>NEMA Class 172-DL</b>	7	7	9	11	14	17	24	30	42	60	74	96

▲ Includes teaser field resistors to limit no load hoisting speed.



# Crane Control Class 6121

## DC Mill Auxiliary Control

### GENERAL INFORMATION

DC mill auxiliary controllers are recommended for use with DC series, shunt, or compound wound motors. They are frequently used on steel mill auxiliary drives such as screwdowns, tables, sideguards, shears, and similar applications. Mill auxiliary controllers can have continuous ratings as well as intermittent and they typically include one less acceleration point than crane drives.

- Mill Duty Class 7004 Type M Line-Arc® contactors & Class 7001 Type K relays
- Class 7001 Type ST-1 static acceleration timers

Five basic control types are available. The equipment supplied as standard on each of these controllers is listed below:

### Reversing Plugging (RP) Control

- 1 Two pole fused control circuit knife switch (CSW)
- 1 Two pole unfused main line knife switch with padlock clip (LSW)
- 1 Surge suppressor for motor shunt field protection (included on panels used with shunt or compound wound motors only)
- 4 Type M single pole directional contactors with mechanical interlocks (1F, 2F, 1R, 2R)
- 3 or 4 Type M single pole acceleration contactors (including one for plugging) (1A, 2A, 3A, P)
- 2 or 3 Type ST-1 static acceleration timers (1AR, 2AR, 3AR)
- 1 Type M single pole negative line contactor (M)
- 1 Type KP rectifier-plugging relay (PR)
- 1 Undervoltage relay (UV)
- 2 Magnetic overload relays (one instantaneous and one inverse time) (1OL, 2OL)

### Reversing Plugging Dynamic Braking (RPD) Control

Includes the same equipment as the reversing plugging (RP) controller, but with the addition of:

- 1 Type M single pole spring-closed dynamic braking contactor (DB)

### Non-Reversing (NR) Control

- 1 Two pole fused control circuit knife switch (CSW)
- 1 Two pole unfused main line knife switch with padlock clip (LSW)
- 1 Surge suppressor for motor shunt field protection (included on panels used with shunt or compound wound motors only)
- 1 Type M single pole positive line contactor (1M)
- 1 Type M single pole negative line contactor (2M)
- 2 or 3 Type M single pole acceleration contactors (1A, 2A, 3A)
- 2 or 3 Type ST-1 static acceleration timers (1AR, 2AR, 3AR)
- 1 Undervoltage relay (UV)
- 2 Magnetic overload relays (one instantaneous and one inverse time) (1OL, 2OL)

### Non-Reversing Dynamic Braking (NRD) Control

Includes the same equipment as the non-reversing (NR) controller, but with the addition of:

- 1 Type M single pole spring-closed dynamic braking contactor (DB)

Consult factory for price and delivery.

## **GENERAL INFORMATION**

### **Reversing Non-Plugging Dynamic Braking (RNPB) Control**

- 1 Two-pole fused control circuit knife (CSW)
- 1 Two-pole unfused main line knife switch with padlock clip (LSW)
- 1 Surge suppressor for motor shunt field protection (included on panels used with shunt or compound wound motors only)
- 4 Type M single-pole directional contactors with mechanical interlocks (1F, 2F, 1R, 2R)
- 2 or 3 Type M single-pole acceleration contactors (including one for plugging) (1A, 2A, 3A)
- 2 or 3 Type ST-1 static acceleration timers (1AR, 2AR, 3AR)
- 1 Type M single-pole negative line contactor (M)
- 1 Type M single-pole spring-closed dynamic braking contactor (DB)
- 1 Type KE non-plugging relay (NP)
- 1 Undervoltage relay (UV)
- 2 Magnetic overload relays (one instantaneous and one inverse time) (1OL, 2OL)

### **Duplex Motor Control – 2 Motors Connected in Parallel**

The duplex controller consists of the equipment for a single motor controller with the exception that all contactors are double pole devices and one additional main line knife switch and two overload relays are added to the controller.

# Crane Control Class 6121

CRANE CONTROL  
CLASS 6121

