

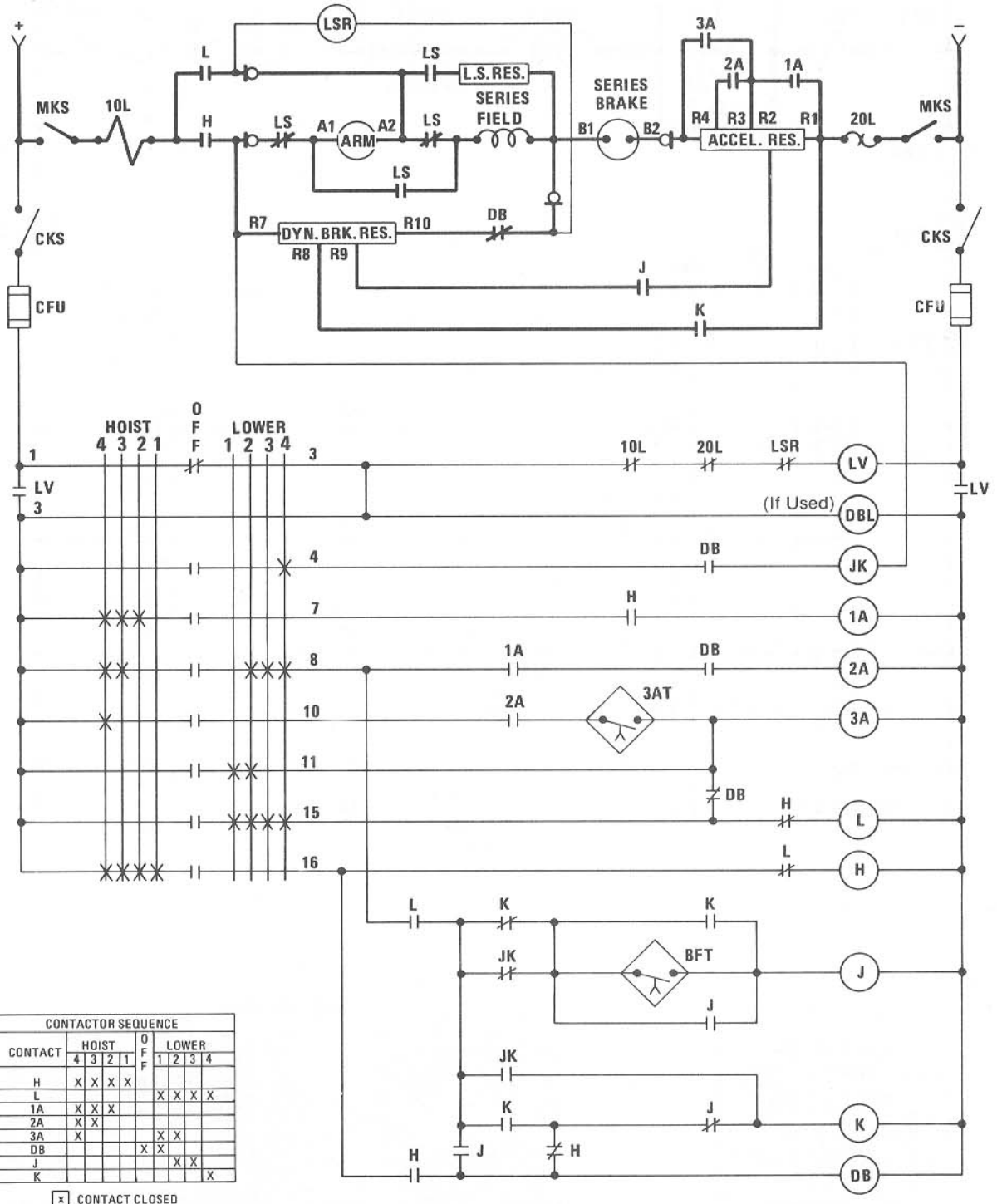

hubbell industrial controls, inc.

# ELEMENTARY DIAGRAM

## TYPE 4121 DC DYNAMIC LOWERING HOIST CONTROLLER



CONTACTOR SEQUENCE								
CONTACT	HOIST			O F F		LOWER		
	4	3	2	1	1	2	3	4
H	X	X	X	X				
L					X	X	X	X
1A	X	X	X					
2A	X	X						
3A	X							
DB					X	X		
J							X	X
K								X

[x] CONTACT CLOSED

MAJOR COMPONENTS			MAJOR COMPONENTS		
SYM	FUNCTION	DESCRIPTION	SYM	FUNCTION	DESCRIPTION
H	HOISTING CONTACTOR	1 POLE NORMALLY OPEN WITH 2 AUXILIARIES	JK	VOLTAGE RELAY	TYPE VR RELAY D.C.
L	LOWERING CONTACTOR	1 POLE NORMALLY OPEN WITH 2 AUXILIARIES	LSR	LIMIT SWITCH RELAY	TYPE VR RELAY D.C.
1A	ACCELERATING CONTACTOR	1 POLE NORMALLY OPEN WITH 1 AUXILIARY	10L	OVERLOAD RELAY	MAGNETIC INSTANTANEOUS TRIP
2A	ACCELERATING CONTACTOR	1 POLE NORMALLY OPEN WITH 1 AUXILIARY	20L	OVERLOAD RELAY	THERMAL INVERSE TIME TRIP
3A	ACCELERATING CONTACTOR	1 POLE NORMALLY OPEN	MKS	MAINLINE KNIFE SWITCH	2 POLE UNFUSED KNIFE SWITCH
J	LOWERING CONTACTOR	1 POLE NORMALLY OPEN WITH 2 AUXILIARIES	CKS	CONTROL CIRCUIT KNIFE SWITCH	2 POLE UNFUSED KNIFE SWITCH 30 AMP
K	LOWERING CONTACTOR	1 POLE NORMALLY OPEN WITH 2 AUXILIARIES	CFU	CONTROL CIRCUIT FUSES	2 FUSES AND CLIPS, 15 AMP, 250 V
DB	DYNAMIC BRAKING CONTACTOR	1 POLE NORMALLY CLOSED WITH 2 AUXILIARIES	BFT	TIMING RELAY	STATIC IN-LINE TIMER
LV	LOW VOLTAGE RELAY	2 POLE RELAY	3AT	ACCELERATING TIMER	STATIC IN-LINE TIMER

# ELEMENTARY DIAGRAM

## TYPE 4120 DC REVERSING-PLUGGING TRAVEL CONTROLLER

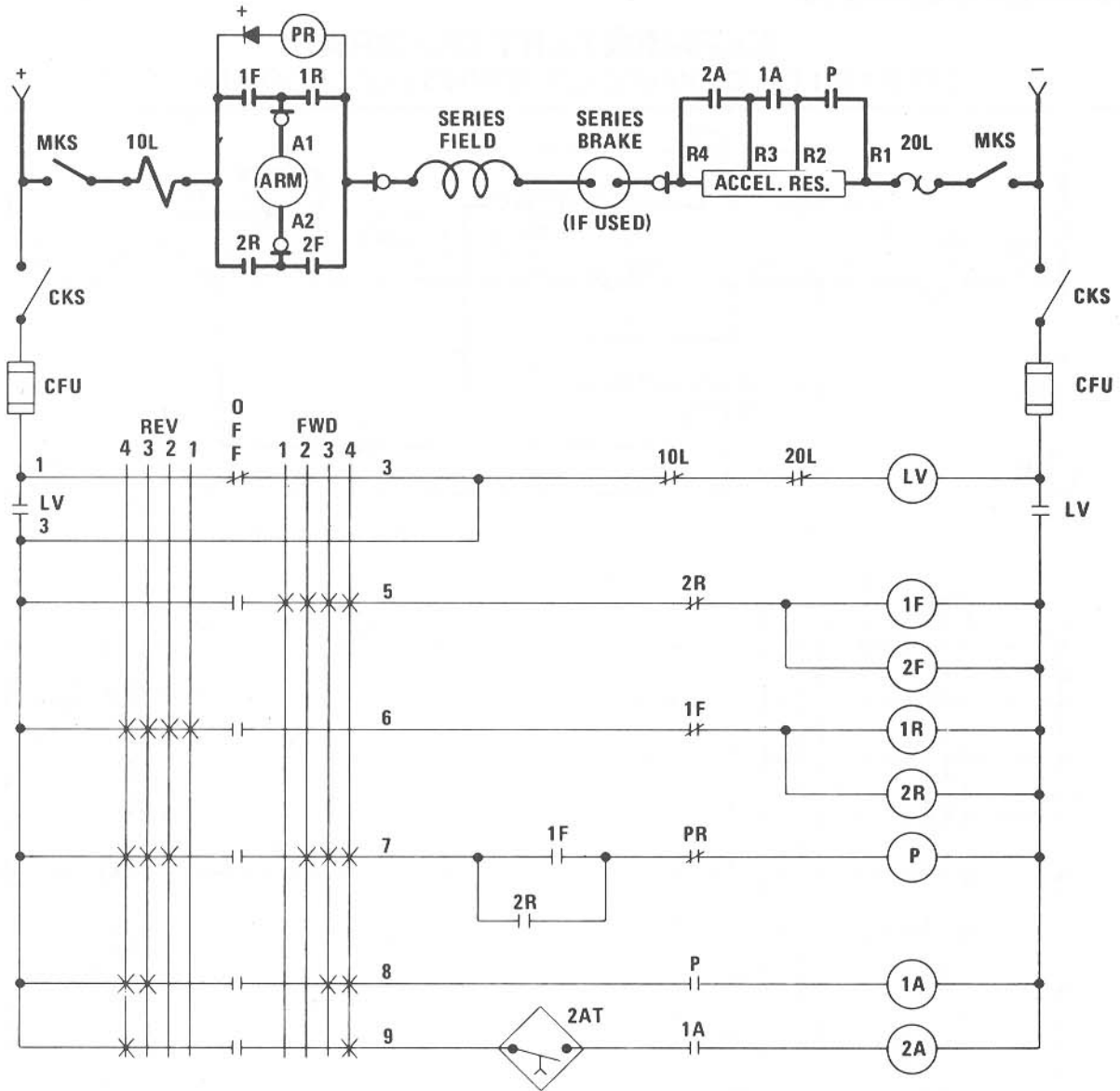

CONTACTOR SEQUENCE									
CONTACT	REVERSE			0	FORWARD				
	4	3	2	1	F	1	2	3	4
1F					X	X	X	X	
2F					X	X	X	X	
1R	X	X	X	X					
2R	X	X	X	X					
P	X	X	X			X	X	X	
1A	X	X				X	X		
2A									X

X CONTACT CLOSED

### MAJOR COMPONENTS

SYM	FUNCTION	DESCRIPTION
1F	FORWARD CONTACTOR	1 POLE NORMALLY OPEN WITH 1 AUXILIARY
1R	REVERSE CONTACTOR	1 POLE NORMALLY OPEN
2F	FORWARD CONTACTOR	1 POLE NORMALLY OPEN
2R	REVERSE CONTACTOR	1 POLE NORMALLY OPEN WITH 1 AUXILIARY
P	PLUGGING CONTACTOR	1 POLE NORMALLY OPEN WITH 1 AUXILIARY
1A	ACCELERATING CONTACTOR	1 POLE NORMALLY OPEN WITH 1 AUXILIARY
2A	ACCELERATING CONTACTOR	1 POLE NORMALLY OPEN
LV	LOW VOLTAGE RELAY	2 POLE RELAY
PR	PLUGGING RELAY	TYPE VR RELAY
10L	OVERLOAD RELAY	MAGNETIC INSTANTANEOUS TRIP
20L	OVERLOAD RELAY	THERMAL INVERSE TIME TRIP
MKS	MAIN KNIFE SWITCH	2 POLE UNFUSED KNIFE SWITCH
CKS	CONTROL CIRCUIT KNIFE SWITCH	2 POLE UNFUSED KNIFE SWITCH, 30 AMP
CFU	CONTROL CIRCUIT FUSES	2 FUSES & CLIPS, 15 AMP, 250 V
2AT	ACCELERATING TIMER	STATIC INLINE TIMER



Hubbell Industrial Controls, Inc.  
 a subsidiary of Hubbell Inc.  
 4301 Cheyenne Dr., Archdale, NC 27263  
 Telephone (336) 434-2800 • FAX (336) 434-2803  
<http://www.hubbell-icd.com>  
[sales@hubbell-icd.com](mailto:sales@hubbell-icd.com)