

General

The Type 4945C S²MC secondary thyristor controller system provides speed-regulated control of hoists with wound rotor motors and eddy current brakes. The Type 4945C system includes the controller and for separate mounting the Type 3000 secondary resistor.

The operator control is a Type 4216 stepless mill master switch. Type 4211 stepless mini master switch or Type 2015/6/7 stepless pendant pushbutton station. Full range of motor speed from minimum to maximum is adjusted by the stepless operator. Hoisting speed, with or without load, is closely controlled by controlling the conduction period of the secondary thyristor modules. No-load lowering speed is handled in the same manner. Lowering speed of an overhauling load at subsynchronous speeds is closely controlled by automatic regulated excitation of the eddy current brake field. For full speed lowering of overhauling loads the eddy current brake field excitation is removed, the thyristors are phased fully on, and the motor regenerates power back into the line.

Type 4945C controllers are available from 5 - 125 HP at 230 VAC and 10 - 250 HP at 460 VAC, 3 phase.

Operation

Hoisting: When hoisting direction is commanded by the operator, the hoisting contactor is closed and hoisting torque is produced by the motor when the secondary thyristor modules begin conduction. The **S²MC Secondary Adjustable Speed Control Assembly** controls the speed of the motor by monitoring the secondary frequency and adjusting the firing angle of the secondary thyristors until the commanded speed is met. The commanded speed is produced by the speed reference signal in proportion to the master switch handle position. Speed is held constant, independent of load, for any given master switch position by the controller.

Lowering: When the lowering direction is selected, the lower contactor is closed and a driving lower torque is produced.

An eddy current brake is coupled to the motor shaft and is controlled by the **S²MC Eddy Current Brake Adjustable Field Supply** to provide retarding torque at subsynchronous speed.

If the hook is lightly loaded, the eddy current brake excitation is kept at a minimum and the controller maintains the motor in a stepless speed regulated driving lower condition.

When an overhauling load, the controller reduces the motor torque and increases the ECB excitation to the level required to maintain the lowering speed commanded by the operator.

The 4945C controller automatically provides either motor driving torque or eddy current brake retarding force as may be required for the commanded speed.

Features

The type 4945C standard controller includes the following major components/features:

S²MC Compact Speed Regulator Assembly consisting of (1) regulator PC board and (1) firing circuit PC board. All adjustments, potentiometers, and test points for setup and fine-tuning plus status lights are front-panel-mounted and clearly identified. Simple test setup readings require use only of a VOM meter.

Three (3) conservatively rated **Type 5410 Full Wave Thyristor Power Modules** with MOV transient voltage protection and snubbing circuits to limit rate of voltage rise. Thyristor modules for 30 HP/460 volt and under are mounted with the S²MC Compact Speed Regulator Assembly. Over 40HP the SCR modules are separate mount within the controller enclosure.

S²MC Eddy Current Brake Adjustable Field Supply consists of a regulator board, firing circuit board, rectifier/filter assembly and eddy current field loss relay protection.

In addition to the S²MC modules the Type 4945C controller features a three pole main knife switch, NEMA rated reversing contactor, (3) Inverse time trip overload relays, fused control knife switch, 120 volt control transformer and low voltage relay.

Optional Features

Full Speed Contactor: The 4945C hoist system requires a secondary slip resistor to provide optimum torque at reduced speeds, but results in a 20% slip at full load/full speed. The full speed contactor shorts out this resistor at high speed and allows the motor to obtain its maximum rated base speed.

Extended Slow Speed Operation: This option allows the hoist to operate at reduced speeds for an extended period of time. Recommended for die handling cranes and turbine handling cranes.

Five Step Reference Board: This option allows the controller to operate from a standard 5 step sequential master switch or pendant. Each step can be independently set for a fixed speed.

Multi-panel Construction: This option provides two or more controllers to be mounted in a common enclosure and interwired with a mainline contactor panel.

Other standard modifications and options are available. Consult factory for assistance.



Block Diagram

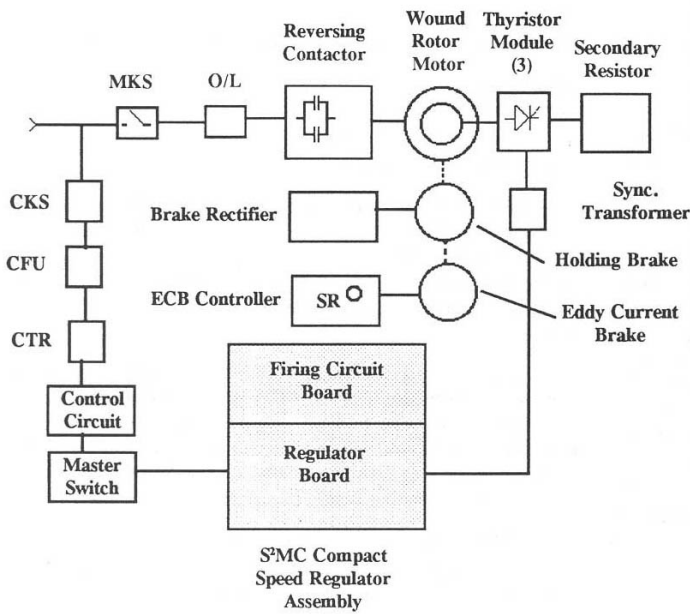

Bill of Material

Description	Symbol	Qty.
Main Knife Switch	MKS	1
Reversing Contactor	F/R	1
Speed Regulator Assembly	SPA	1
Eddy Current Brake Assembly	ECB	1
Thyristor Modular	SCR	3
Overload Relays	OL	3
Low Voltage Relay	LV	1
Control Knife Switch	CKS	1
Control Fuses	CFU	3
Control Transformer	XFRRI	1

Specifications

Input Power	Standard: 230/460 60hz., Other voltages available
Horsepower Range	5 - 30HP for Compact Construction. 50 - 250HP with external SCR's
Speed Range	Typical 10 to 1
Speed Regulation	10% Typical
Control Configuration	Contacting reversing. Eddy current brake for hoisting and anti-coast services.
Temperature Range	- 40 degree C to + 55 degree C.

Speed/Torque Curve

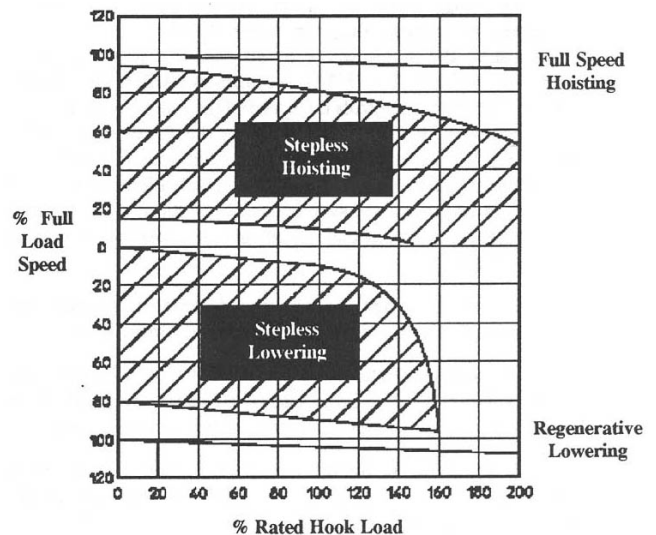

Hubbell Industrial Controls, Inc.

A subsidiary of Hubbell Incorporated

4301 Cheyenne Dr., Archdale, NC. 27262

Telephone (336) 434-2800 • FAX (336) 434-2803

<http://www.hubbell-icd.com>

Sales@hubbell-icd.com