



Replacement Parts

58-GTT3

November 2003

Reversing Drum
Controllers
Class 58
TT3

INDEX	PART NO.	PCS. REQD.	NAME OF PART
1	D03887-002	1	Frame assembly complete with insulation, spring and lever posts
2	D10445-002	1	Frame insulation
5	D06517-002	2	Fingerboards, (left or right hand)
6	D00925-004	12	Fingers complete with copper tips
7	D56163-001	1	Rotor assembly consisting of: cam, shaft rotor contacts, inner and outer tubing and arc shields
8	D00103-040	1	Shaft
9	D09944-001	1	Cam
10	*D01605-002	1	Rotor contact
11	*D01605-004	1	Rotor contact
12	*D01605-006	1	Rotor contact
13	D35281-002	4	Rotor sleeve
14	D01858-027	4	Outer tubing
15	D01858-049	1	Outer tubing
16	D00379-001	1	Arc shield
17	D00379-002	3	Arc shields
18	D08340-001	1	Top assembly complete w/ bushing
19	D17731-004	1	Lever
20	D00114-001	1	Red Knob
21	D06227-001	1	Index lever assembly
22	*D09953-001	1	Index Spring
23	D06196-010	1	Spacer

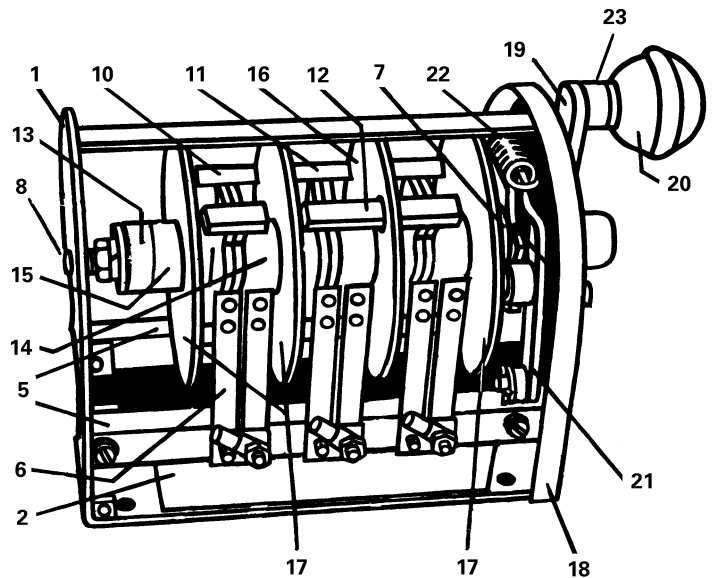

* PK41 Parts Kit

Wiring Diagram

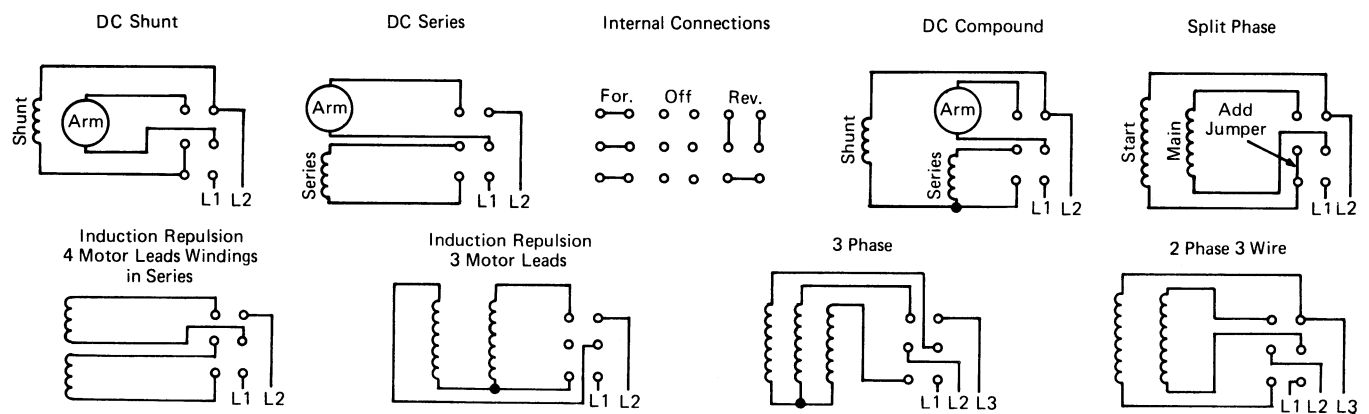

* Add Jumper for Split Phase applications.

NOTE: When ordering replacement parts, give complete catalog number of switch and part number.

(For Engineering Reference Only - Rev. B)