



TYPE HCO-1, SERIES B, NEMA SIZE 1, 25 AMPERE, DC CONTACTOR SINGLE POLE, NORMALLY OPEN

INSTALLATION AND ADJUSTMENT

Mount the contactor vertically on a rigid support. Provide at least .6" clearance above the top of the contactor base and 1.7" in front of the arc chute for arcing clearance and arc chute removal.

● With the contactor power OFF, lift straight up on the arc chute (1) and remove it from the contactor. Operate the contactor by hand to see that the contact tips meet squarely. If they do not, adjust by the procedure described below in step 9 of "Contact Tip Replacement". When released, the contactor should open freely. If it does not, check for the impaired operation of the contact arm assembly. Check all electrical connections to see that they are tight and replace the arc chute. No further adjustments are necessary.

CAUTION: Do not operate the contactor under load without the arc chute installed in its proper position.

TROUBLESHOOTING

PROBLEM: Contactor will not close when energized.

● **SOLUTION:** Check the voltage at the operating coil terminals. An absence of voltage indicates a fault elsewhere in the circuitry. If the coil voltage is normal, disconnect the coil leads and check the coil for proper resistance. Resistance values for the standard coils are listed in the parts list on page 2. Resistance values for other coils are listed in the Class 9998 Magnet Coil Application Data catalog sheet. An open or shorted coil must be replaced.

REPAIR and MAINTENANCE

CONTACT TIP REPLACEMENT

To determine when the contact tips should be replaced, the contact follow up must be measured. The contact follow up is the distance "F" measured at the upper edge of the contact arm with the contactor fully closed, as shown on the right. When this distance is reduced to 1/32" or less, the contact tips must be replaced to assure that proper contact pressure is maintained.

Should it be necessary to replace the tips, a screwdriver is the only tool needed and the following procedure should be followed:

1. Lift straight up on the arc chute (1) and remove it from the contactor.
2. Unscrew the arc horn assembly (43), and remove the flexible connector and movable contact tip.
3. Loosen the two pan head screws (22) and push the contact arm pin (23) out.
4. Remove the contact arm assembly and unscrew the screw (41) holding the stationary contact tip in place.
5. Install the new stationary contact tip (39), screw (41)*, and lock washer (40)*.
6. Replace the contact arm assembly making sure that the opening spring (31) is seated

properly over the head of screw 29.

7. Replace the contact arm pin (23), tighten the two pan head screws (22).
8. Reassemble the new movable contact tip (42), flexible connector (24), and arc horn (43), in that order.
9. Operate the contactor by hand to see that the tips meet squarely. Contact tip alignment can be adjusted by loosening the tip retaining screws and shifting the tips. After the contacts are properly aligned, retighten the screws securely.

10. Replace the arc chute.

COIL REPLACEMENT

To replace the operating coil, a screwdriver is required and the following procedure should be followed:

1. Lift straight up on the arc chute (1) and remove it.
2. Remove the coil leads.
3. Loosen the two pan head screws (22) and push the contact arm pin (23) out.
4. Remove the contact arm assembly.
5. Unscrew the screw (29) on the top of the magnet core and remove the coil.

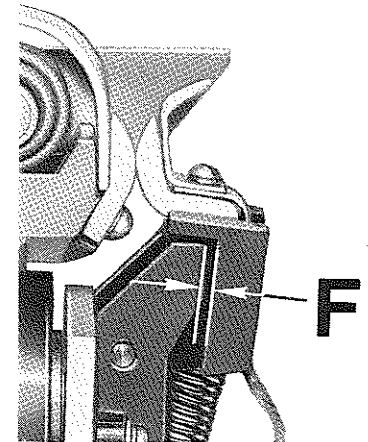
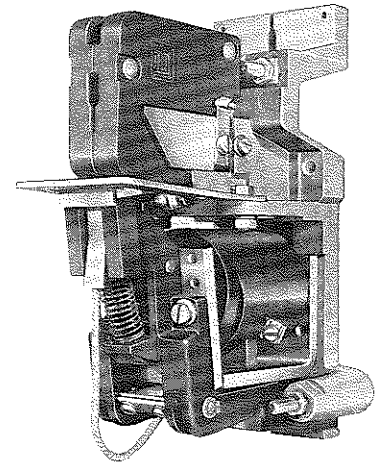

6. Install the new coil and replace the core cap (26), the core cap spacer (27), lock washer (28), and screw (29). Make sure the core cap (heavy steel washer) is next to the coil.
7. Replace the contact arm assembly, making sure that the opening spring (31) is seated properly over the head of screw 29.
8. Replace the contact arm pin (23) and tighten the two pan head screws (22).
9. Reconnect the coil leads to the new coil and replace the arc chute.

LUBRICATION

The type "H" contactor requires no lubrication. The pivot pins bear in a self-lubricating material.

NOTE: *The special non-magnetic bolts and lockwashers supplied with the contact parts kit must be used.
*Minor revision since previous issue.



TYPE HCO-1, SERIES B, NEMA SIZE 1, 25 AMPERE, DC CONTACTOR, S.P., N.O.

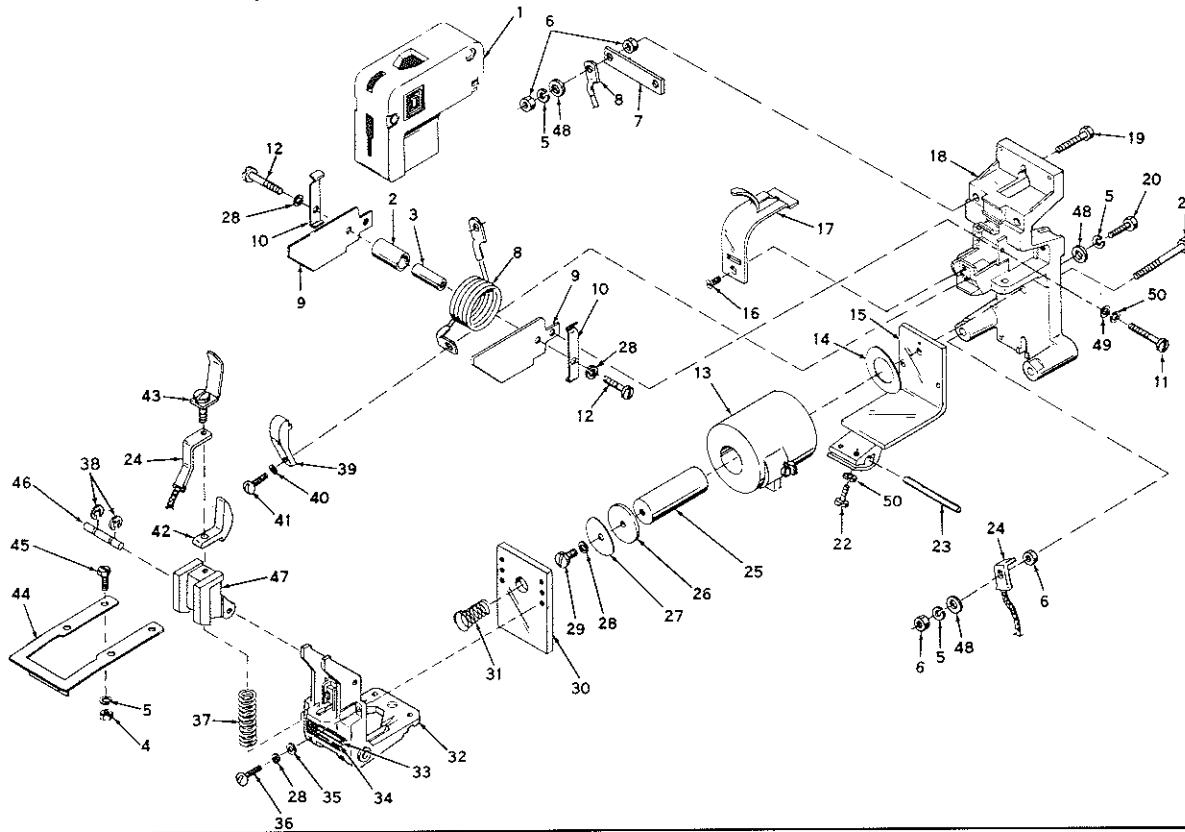

Item No.	Part No.	Description	Item No.	Part No.	Description
* 1	A51015-035-50	Assembled Arc Chute	25	A51015-040-50	Assembled Coil Core
2	B50512-052-29	Blowout Core Insulator	26	B50502-006-08	Core Cap
3	B50502-776-06	Blowout Core	27	B50502-006-09	Core Cap Spacer
• 4		1/4" - 20 Hex Steel Jam Nut, 2 Req'd.	• 28		#10 Plain Lock Washer, 5 Req'd.
• 5		1/4" Plain Lock Washer, 5 Req'd.	• 29		#10 - 24 x 3/8" Pan Head Steel Screw
• 6		1/4" - 20 Hex Steel Nut, 4 Req'd.	30	A51015-043-01	Armature
7	A51015-119-01	Terminal Tie Bar	31	B50502-602-07	Opening Spring
8	A51015-030-50	Assembled Blowout Coil	32	C51015-103-50	Contact Arm Assembly with Bushings
9	A51015-032-01	Blowout Ear, 2 Req'd.	33	A51139-173-03	Nameplate
10	A51015-034-01	Arc Shield Spring, 2 Req'd.	• 34		#6 - 32 x 1/4" Pan Head, Type F, Tapping Screw, 2 Req'd.
• 11		#8 - 32 x 3/8" Hex Pan Head, Tri-Lobe Screw, 2 Req'd.	• 35		#10 Plain Washer, 2 Req'd.
• 12		#10 - 24 x 1/2" Hex Head Steel Screw, 2 Req'd.	• 36		#10 - 24 x 5/8" Pan Head Steel Screw, 2 Req'd.
* 13	A51015-056-50	Assembled Operating Coil (240V. Approximate Resistance 2114 ohms)	37	B50502-602-18	Auxiliary Arm Spring
	A51015-056-51	Assembled Operating Coil (120V. Approximate Resistance 543 ohms)	38	29907-01410	"E" Rings
14	A51017-041-01	Spring Washer	* 39		Stationary Contact Tip
15	A51015-076-50	Assembled Magnet Frame	* 40		#10. Silicon Bronze Lock Washer
• 16		#6 - 32 x 1/4" Flat Head Steel Screw	* 41	Class 9998 Type HC-1 Kit	#10 - 24 x 1/2" Round Head Silicon Bronze Screw
17	A51015-033-01	Blowout Guard	* 42		Movable Contact Tip
18	C51015-028-50	Assembled Contactor Base	* 43		Assembled Arc Horn
• 19		1/4" - 20 x 1" Hex Head Steel Screw, 2 Req'd.	44	A51015-053-01	Stop Plate
• 20		1/4" - 20 x 7/8" Hex Head Steel Screw	• 45		1/4" - 20 x 5/8" Hex Head Slotted Steel Screw, 2 Req'd.
• 21		1/4" - 20 x 1 3/4" Hex Head Steel Screw, 2 Req'd.	46	A51015-059-01	Auxiliary Arm Pin
• 22		#8 - 32 x 3/8" Pan Head Screw, 2 Req'd.	47	B51015-145-50	Auxiliary Arm
23	A51015-102-01	Contact Arm Pin	• 48		1/4" Plain Washer, 3 Req'd.
24	A51016-050-50	Assembled Connector	• 49		#8 Plain Washer
			• 50		#8 Plain Lock Washer

■ Standard hardware, listed without a Square D part number, should be obtained from a local hardware supplier.
 *Essential Parts for General Maintenance.
 •Minor revision since previous issue.