

Crane Control Class 7001

Catalog

03



CRANE CONTROL
CLASS 7001

CONTENTS

Description	Page
Type K DC Relays	100
Type ST DC Static Timer	106
Type SSI DC Acceleration Module	107



The Electric Controller and
Manufacturing Company, LLC

Crane Control Class 7001

Type K DC Relays



Class 7001
Type K
DC Relays

SELECTION GUIDE

- Mill duty construction
- Designed for steel base mounting
- 10 A continuous rating
- 600V DC maximum

Type KG General Purpose Relay	<ul style="list-style-type: none"> • Used for general purpose relaying applications • Available with up to 4 double pole single throw contact blocks • Uses shunt operating coils
Type KP Plugging Relay	<ul style="list-style-type: none"> • Used on DC reversing plugging control panels to detect motor plugging operations • Available with one normally closed contact • Rectifier in series with operating coil
Type KE Voltage Sensitive Relay	<ul style="list-style-type: none"> • Recommended for applications requiring voltage sensitive adjustable relays • Frequently used for sensing DC motor armature voltage • Available with up to 2 double pole single throw contact blocks
Type KF Field Relay	<ul style="list-style-type: none"> • Recommended for controlling DC motor shunt fields and other inductive loads such as groups of relay or contactor coils • Used as UV relay on control panels • 25 ampere continuous rating • Single-pole, normally-open or normally-closed contact with permanent magnet blowout
Type KI Current Sensitive Relay	<ul style="list-style-type: none"> • Recommended for applications requiring current sensitive adjustable relays • Frequently used for sensing DC motor current • Available with up to 2 double-pole, single-throw contact blocks

For dimensional information, see page 105.

Application Data for All Type K Relays

Wiring

All wires can be terminated directly at the relay. Each contact block has self-aligning, captive screw type wire clamps. Similar wire clamps are used on the coil terminals. Since these relays are completely front mounted and connected, all wires are accessible from the front.

Mounting

The Type K relays make use of a steel mounting plate and can therefore be mounted directly onto a steel pan or a steel framework structure of suitable dimensions.

Contacts

All Type K relays with the exception of the Type KF field relay use the same basic contact block. Each control circuit block contains one normally open and one normally closed contact. The contact block on the Type KG, KE, and KI Relays is rated in accordance with NEMA Standard ICS2-125-2 for a heavy duty rating. The Type KF relay uses heavy duty contacts equipped with a permanent magnet blowout.

See Class 9999 catalog section for replacement contact block kits.

Contact Ratings

Relay Type	Continuous Current	System Voltage	Interrupting Rating (Inductive)
KG KE KI	10 A	115-125 230-250 550-600	2.2 A 1.1 A 0.4 A
KF	25 A	115-600	25.0 A ① 15.0 A ②

① The Type KF relay can interrupt 25 A when used to switch resistance in a motor shunt field circuit. Examples are relays designated as FA, FFA, FK, and FD.

② The Type KF relay interrupting rating is limited to 15 A when the relay is used to switch highly inductive circuits consisting of contactor and relay combinations. A typical example would be a low voltage protective relay, designated UV.

Coil Data

For complete coil data refer to the Class 9998 Coil Data Catalog Sheets beginning on page 152.

Crane Control Class 7001 Type K DC Relays

PRICING INFORMATION AND APPLICATION DATA

Type KG General Purpose Relay

Type KG relays are recommended for general purpose relaying applications. The shunt operating coils are designed in accordance with NEMA standards to withstand 110% of rated voltage continuously and to operate successfully at 80% rated voltage.

Total Number of Control Circuit Contacts		Open Type	
N.O.	N.C.	Type	Price
1	1	KGO11	\$ 468.
2	2	KGO22	576.
3	3	KGO33	684.
4	4	KGO44	792.

Ordering Information Required:

1. Class
2. Type
3. Coil Voltage

**CRANE CONTROL
CLASS 7001**

Type KP Plugging Relay

To insure proper operation, the Type KP relay is furnished with a coil rated for one half the system voltage. See Class 6121 or Class 6131 catalog sheets for typical plugging relay connection on reversing plugging bridge and trolley drives.

The relay is furnished with one normally closed contact. Relay KPO2 operates when the motor approaches standstill and is thus suitable for use on a single-step plugging scheme or as the final step in a two-step plugging scheme. Relay KPO5 operates at about motor full load speed and is therefore used in the first plugging step of a two step scheme. To achieve the correct pick-up and drop-out characteristics, relay KPO5 includes a resistor and capacitor mounted to the relay base.

Relay Function	System Voltage ★	Contacts	Open Type	
			Type	Price
Single-step plugging system or second step for two point plugging system	240	1 N.C.	KPO2	\$ 531.
First step for two-point plugging system	240	1 N.C.	KPO5	666.

★ For other voltages, consult factory.

Ordering Information Required:

1. Class
2. Type

CP9B		Discount Schedule
------	--	----------------------



Crane Control Class 7001

Type K DC Relays

PRICING INFORMATION AND APPLICATION DATA

Type KE Voltage-Sensitive Relay

Application Data – Adjustment Range

Relay pick-up is adjustable between .20 and 1.34 of rated coil voltage. Relay drop-out is adjustable between .04 and .98 of rated coil voltage. The total adjustment range is obtainable by the use of various springs and core caps. Pick-up and drop-out adjustments are not independent. No single relay is available with the entire adjustment range.



**Class 7001
Type KEO11
Relay**

Applications

Relay Designation	Relay Function	Type	Coil VDC	Relay Setting
LSR	Limit Switch Relay used on Class 6121 FRONTLINE® hoist control panels with Type H and M contactors.	KEO11	120	55V P.U.
LSR	Limit Switch Relay used on Class 6110 or Class 6121 hoist control panels with Type L Line-Arc® contactors.	KEO22	120	55V P.U.
NP	Non-Plug relay for compound and shunt motors.	KEO22	240	Min. D.O.
VR	Voltage relay initiates high speed lowering on hoist controllers.	KEO11	240	110V P.U.
VR	Voltage relay used on reversing-plugging controllers with Emergency or Service Dynamic Braking.	KEO11	240	Min. D.O.
1VR 2VR	Voltage relays used on hoist controllers. 1VR initiates high speed lowering. 2VR functions as an overspeed relay.	KEO11 KEO11	120 120	110V P.U. 250V P.U.
VR	Voltage relay used to control application of armature shunt contactors on multi-step slowdown circuits.	KEO11	as required	as required
VR	Voltage relay used for over voltage protection on adjustable voltage controllers.	KEO11	as required	as required
VR	Voltage relay used for clamping circuit to provide fast start in slow speed operating range of controller.	KEO11	as required	as required

Total Number of Control Circuit Contacts		Open Type	
N.O.	N.C.	Type	Price
1	1	KEO11	\$558.
2	2	KEO22	666.
3	3	KEO33	774.
4	4	KEO44	882.

Ordering Information Required:

1. Class
2. Type
3. System Voltage
4. Pick-up and/or drop-out setting. If both pick-up and drop-out settings are required, also specify which is most important.

CP9B Discount Schedule



Crane Control Class 7001 Type K DC Relays

Type KF Field Relay

Applications

Relay Designation	Relay Function	Type
FA	Acceleration of adjustable speed motors on weakened field. (Requires provision on the control with which it is used, for short-circuiting the relay contacts in order to provide full field during acceleration to base speed.)	KFO10 through KFO18
FFA	Acceleration of adjustable speed motors on weakened field and provides full field during acceleration to base speed.	Consult Factory.
FK	Acceleration and deceleration of adjustable speed motors. Provides full field during acceleration to base speed and during dynamic braking for stopping; also provides for acceleration on weakened field.	KFO50 through KFO58
FD	Deceleration of adjustable speed motors by alternately strengthening and weakening the shunt field during dynamic braking.	KFO50 through KFO58 Form NC
UV	Low voltage protective relay used on DC crane and mill controllers with protection.	KFO70 through KFO73

Coils		Contacts ■	Open Type	
Type	Max. Continuous Amperes ▲ (Series Coil)		Type	Price
1 Series	7.4 11.7 18.8	1 N.O.	KFO10 KFO11 KFO12	\$ 770.
	29.5 46.9 73.6	1 N.O.	KFO13 KFO14 KFO15	770.
	114 172 258	1 N.O.	KFO16 KFO17 KFO18	770.
1 Series and 1 Shunt	7.4 11.7 18.8	1 N.O.	KFO50 KFO51 KFO52	770.
	29.5 46.9 73.6	1 N.O.	KFO53 KFO54 KFO55	770.
	114 172 258	1 N.O.	KFO56 KFO57 KFO58	770.
1 Shunt	240 V 120 440 550	1 N.O.	KFO70 KFO71 KFO72 KFO73	770.

- For 1 N.C. contact in place of N.O. contact, specify Form NC
- ▲ Pick-up and/or drop-out adjustment range is obtainable by use of various springs and core caps.

Ordering Information Required:

1. Class
2. Type
3. Form (Normally open or normally closed)
4. System voltage (for shunt applications only) or Continuous current (for series applications only)
5. Pick-up and/or drop-out settings. If both pick-up and drop-out settings are required, also specify which is most important.

CP9B

Discount
Schedule

Crane Control Class 7001

Type K DC Relays

Type KI Current Sensitive Relay

Application Data

For low currents, the terminals are on the operating coil. For higher current applications a wire wound or strap wound coil is used. Coil leads are brought to a power termination block at the top of the relay.

Adjustment Range

Relay pick-up is adjustable between .24 and 1.34 of rated coil current. Relay drop-out is adjustable between .20 and .98 of rated coil current. The total adjustment range is obtainable by the use of various springs and core caps. Pick-up and drop-out adjustments are not independent. The ratio of drop-out setting to pick-up setting of the relay must be between .13 and .85

Applications

Relay Designation	Relay Function	Type
FL	Field Failure Relay for compound and shunt motors.	KIO11
JR	Jam Relay limits stall torque on series motors.	KIO11
LR	Load Relay operates at a preset current (load).	KIO11
SR	Series Relay used as shunt brake interlock relay.	KIO11

Total Number of Control Circuit Contacts		Open Type	
N.O.	N.C.	Type	Price
1	1	KIO11	\$ 603.
2	2	KIO22	711.

Note: Maximum coil rating 258 A continuous. For higher current coils consult factory.

Ordering Information Required:

1. Class
2. Type
3. Continuous current
4. System voltage
5. Pick-up and drop-out settings

CP9B		Discount Schedule
------	--	-------------------



CRANE CONTROL CLASS 7001

Crane Control Class 7001 Type K DC Relays

APPROXIMATE DIMENSIONS AND WEIGHTS

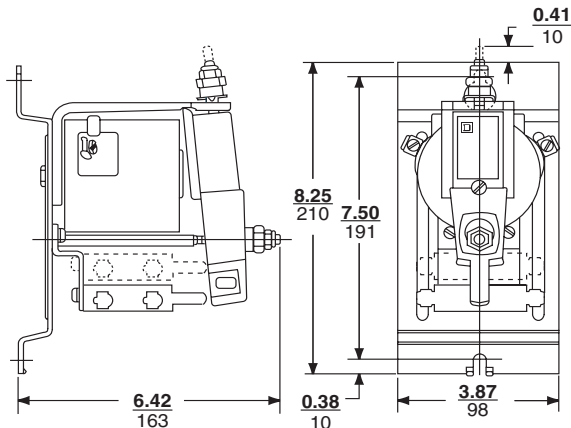

Type KGO11 and KGO22, Type KEO11 and KEO22,
Type KPO11, Type KIO11 and KIO22
(with Form Wound Coils)

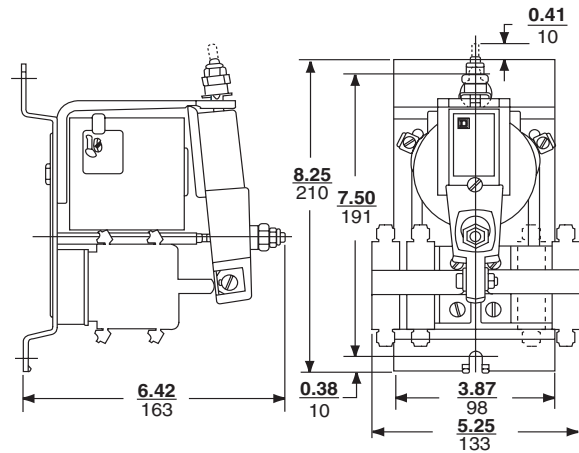

Type KGO33 and KGO44

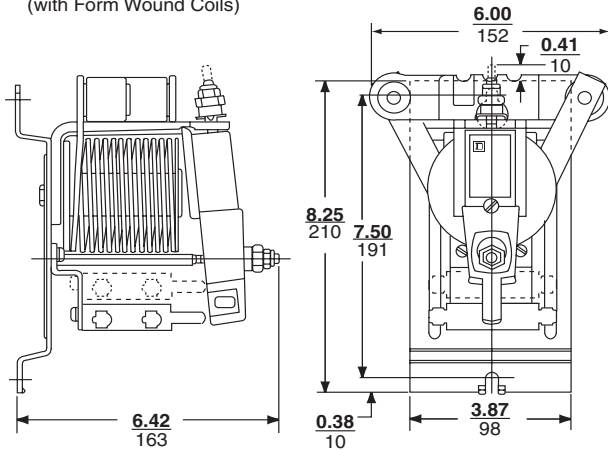

Type KIO11 and KIO22 (with Strap Wound Coils)

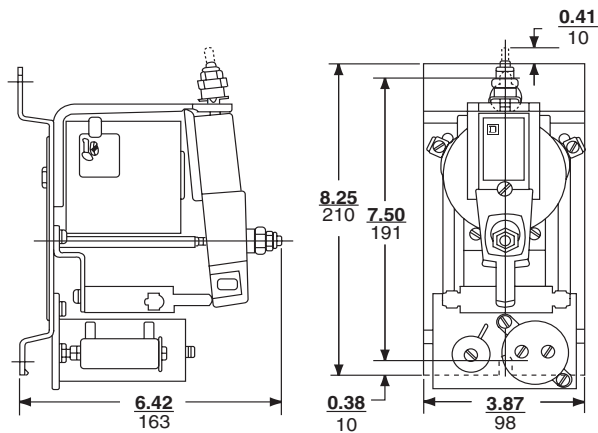

Type KPO5

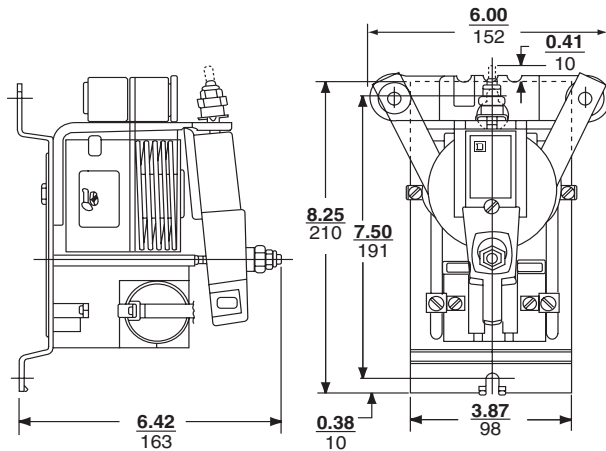

Type KFO10 thru KFO69

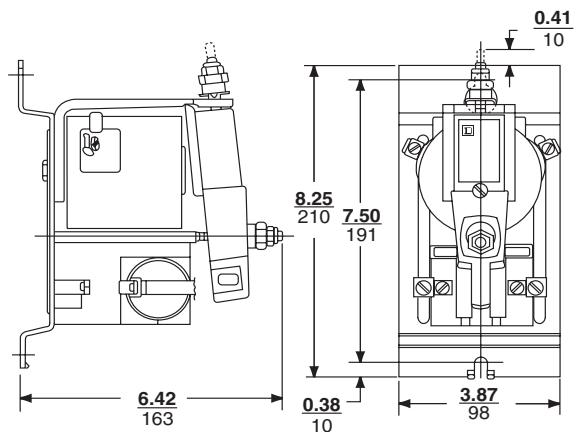

Type KFO70 thru KFO73

All relays have two mounting holes for 1/4" screws.

Weight - 7 lbs (3.2 kg)

Enclosed Type

Minimum recommended dimensions for enclosure for all Type K relays –
Height: 16", Width: 12", Depth: 8".

Dual Dimensions $\frac{\text{inches}}{\text{mm}}$



Crane Control Class 7001

Type ST DC Static Timer



Class 7001
Type ST1
Static Timer

PRICING INFORMATION AND APPLICATION DATA

Class 7001 Type ST Static Timers are used to control closure of accelerating contactors on DC panels.

- Three time delay settings
- Encapsulated DC timing relay consisting of solid state circuit components

Class	Type	Voltage Rating	Current Capacity	Price
7001	ST1	200/300 VDC	1 A @ 55 °C	\$ 216.
	ST2	300/500 VDC	0.65 A @ 55 °C	216.
	ST3	500/600 VDC	0.65 A @ 55 °C	216.

Application Data

The static timer is wired in series with the acceleration contactor coil and appears as a normally open timed closed contact. Voltage applied across terminals 1-3 initiates a 0.6 second time delay, whereas voltage applied across terminals 2-3 initiates a 1.2 second time delay (for time delay of 3 seconds, clip jumper wire on top). (Terminal 3 is always connected to the power supply negative.) Upon completion of the timing cycle the static timer appears as a contact closure and allows energization of the contactor coil.

Arc suppressors installed in the control circuit must be connected in parallel with the series combination of static timer and contactor coil as shown below.

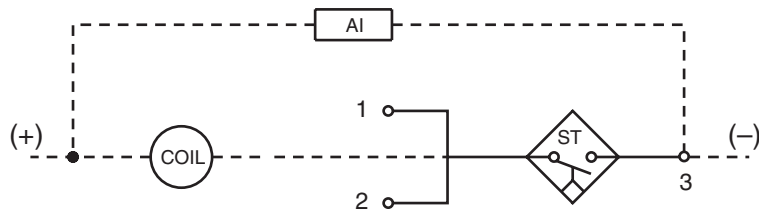

NOTE: Erratic operation of the static timer may result if an arc suppressor is located directly across the contactor coil.

Time Delay	Seconds	Terminals
	0.6	1(+)-3(-)
1.2	2(+)-3(-)	
Operating Temperature	-20 to +85 °C	
Load Impedance (Maximum)	3K ohms	

Approximate Dimensions

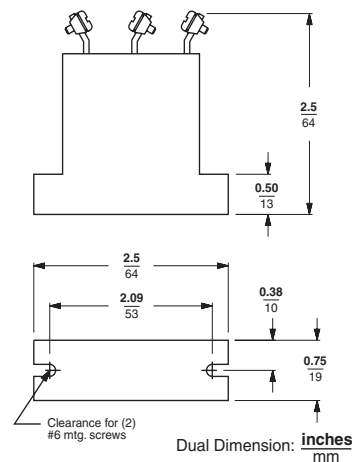

Ordering Information Required:

1. Class 7001
2. Type

CP9B Discount Schedule



Crane Control Class 7001 Type SSI DC Acceleration Module

PRICING INFORMATION AND APPLICATION DATA



**Class 7001
Type SSI
Acceleration Module**

Class 7001 Type SSI accelerating modules are recommended for use in DC motor circuits and are used to control the closure of the accelerating contactors on DC control panels.

- Time delay depends on motor current
- Single module provides up to 4 steps of acceleration control using 4 replaceable output power thyristor units
- No power connections required—motor current signal obtained from voltage drop across last acceleration resistor step
- Indicating light monitors module operation

Type	Acceleration Steps	Price
SSI03	3	\$ 1350.
SSI04	4	1575.

Application Data

The Type SSI module is used to control closure of the acceleration contactors on DC crane and mill panels. Proper DC motor acceleration is achieved by the module monitoring motor current and automatically adjusting the timing period between acceleration contactor closure.

A sixteen position switch is used to adjust a current set point to equal 100% of motor full load current for hoist drives and 50% of motor full load current for travel drives. When the acceleration current falls below the set point, or the maximum time has elapsed, the next acceleration circuit is energized.

A 15 ampere (maximum) fuse should be installed in the control circuit for proper protection of printed circuit board foil runs.

If arc suppressors are installed on the contactor coils, it is necessary that they be connected from the positive side of the contactor coil to the power supply negative.

NOTE: Erratic operation may result if the arc suppressors are located directly across the contactor coils.

Voltage Range	200-300 VDC
Current Capacity	0.36 A at 85 °C
	1.00 A at 55 °C
Time Delay ▲	0.1 to 1.0 seconds
Operating Temperature	-20 to +85 °C
Load Impedance (Maximum)	3K ohms

- ▲ On hoist controllers the time delay is increased from 0.5 to 1.0 seconds on the first point of acceleration in the lowering direction to ensure brake release.

Approximate Dimensions

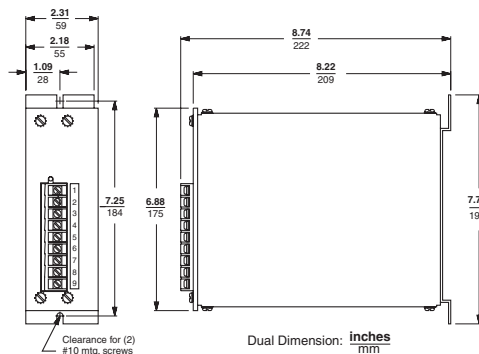

Ordering Information Required:

1. Class
2. Type

CP9B Discount Schedule

